

111-14.

JUNE, 1888.

21 0 '88

E.P.C. 111

HOW TO MAKE
 2
 PHOTOGRAPHS
 AND
 DESCRIPTIVE PRICE LIST.

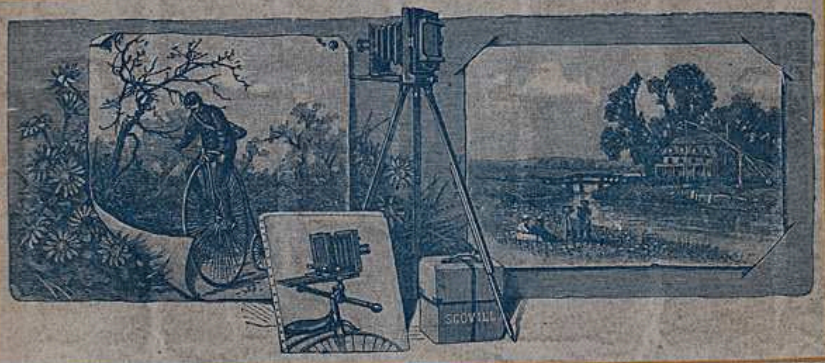

JOHN WANAMAKER,

Chestnut, Market and Thirteenth Streets,

PHILADELPHIA.

HOW TO MAKE PHOTOGRAPHS.

PICTURE making is quite simple, and the details are therefore briefly given. Any person of average intelligence may feel certain that he can succeed in making good photographs if he purchases an equipment made by reliable manufacturers.

Filling the Plate Holder.—If this is done in the daytime, a closet or room is selected and all white light excluded from it. It is a difficult task to make this exclusion absolute. One ray of white light will spoil a sensitive plate, and therefore the evening is generally chosen to develop negatives, and for illumination

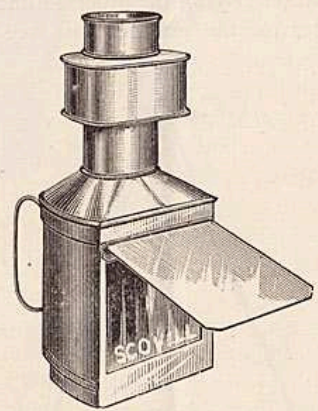

W. I. A. PETITE LANTERN.

the light from a ruby lantern is employed. Open a package of gelatine plates (these plates are glass, with a coating of gelatine on one side) and place one of them in a Dry Plate Holder, with the sensitive (not the glossy) side facing outward. Handle the plates as shown in the outline cut. After putting into the holders as many plates as are needed for a day's work, pack the outfit so that it can be conveniently carried about.



Taking the Picture.—For field service, a camera, a number of plate holders filled with sensitive plates, a lens, tripod, carrying case, and focusing cloth are needed. When these have



Amateur with Kit Packed.

been taken to a place where the view looks inviting, fasten the camera on the tripod, throw the focusing cloth over your head, gather it under your chin, draw out the back of the camera, thus extending the bellows, and continue the movement until the image on the ground glass appears most distinct, then fasten the back of the camera. This is called "focusing." At the first glance an inexperienced person sees no reflection on the ground glass, but the eye soon

becomes practiced to perceiving the inverted image there. Substitute a plate holder for the ground glass, see that the cap is

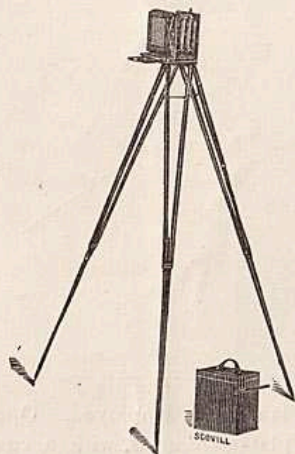

Apparatus set up.

on the lens, pull the slide out of the holder, and place it on the top of the camera, or in a convenient place. If everything is now in readiness, and the time for exposing the sensitive plate

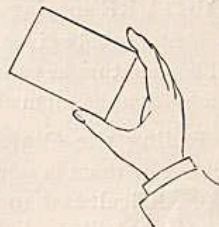

Plate in hand.

determined, uncap the lens, recapping it at the end of the allotted time and replacing the slide in the holder.

Make an entry on the Registering Slide of a similar import to this:

After you have picture impressions on each sensitive film, rearrange your outfit in compact shape and return home.

Making Negatives.—

Amateurs may content themselves with making the exposures and sending their plates in a light-tight negative box to some photographer, who, for a small price, will produce the finished pictures and mount them on card-board or in albums.



Registering Slide. (Patented.)

It is not essential, where one attends to these details himself, that they should be done at once. Months may elapse, and these Dry Plates be carried hundred of miles without deterioration.

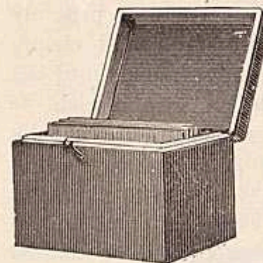

Negative Box.

The Chemical Outfit for making negatives comprises the following articles: Two glossy rubber trays, a 4 ounce glass graduate, a minim graduate, a ruby lantern, a bottle of S.P.C. negative varnish, 1 dozen dry plates, an ounce of bromide of ammonium, a pound of hyposulphite of soda, 1 pound of alum, and a package of S.P.C. carbonate soda developer.

These chemicals are not dangerous nor do they emit offensive odors. Silver stains and the disagreeable smell of collodion belong to the old "wet" process.

The exposed plates must be removed from the holder in a dark room illuminated by a feeble red or orange light. Take them out of the holder, carefully handling them by the edges and place one of them, film side up, in a tray of pure water*. While it soaks there prepare the developer in the following manner; Dissolve the contents of the paper package marked No. 2, of the

*The Russell Negative Clasp and Drying Support for holding dry plates during development and drying is certainly to be recommended for convenience, and because it keeps the fingers out of the developing solutions. It also enables one to hold the plate up and note the progress of development without touching the sensitive surface of the plate. (See illustration on page 5).

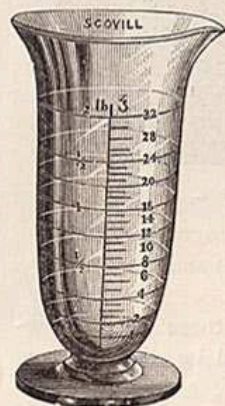

Graduated Glass.

carbonate soda developer in 64 ounces of water, and label this "Solution No. 2;" and with the minum glass add to 2 ounces of this solution 2 drams of the No. 1 solution. Now pour off the water from the tray, and flow over the plate the combined developing solution. If air-bubbles form on the plate they must be removed by a touch of the finger or by a soft camel's hair brush. If the plate be correctly exposed traces of the image will appear on the sensitive film in a short time, but in case they do not, pour the developing solution back into the graduate and add a little more of No. 2 solution (from a quarter to half an ounce) and reflow the plate with the strengthened developer. In a short time the details of the image will appear, but wait patiently until all the details are out and clearly seen in the deep shadows, and until the milky-white appearance of the plate is

changed to a dark gray color. The negative is then fully developed and must be washed in two changes of water, when it is ready for the "fixing" bath. Should the image on the plate flash out suddenly on flowing it with the developing solution, and continue to grow very rapidly, the plate has been over-exposed and must be quickly removed from the developing tray and placed in pure water while a restraining solution of bromide is made as follows: Dissolve 1 ounce of bromide of ammonium in 8 ounces of water, and label "Bromide solution." Now add a few drops of the bromide solution to the developing tray and replace in it the partly developed plate. The development will now proceed more slowly, but if too much bromide has been added, so that the development is entirely stopped, it can be started again by adding carefully a little more of the No. 2 solution.

In the unused tray mix a solution of 4 ounces of hyposulphite of soda and 20 ounces of water. Label this tray "Hypo." and do not use it for any other purpose. After washing the negative place it in the hypo. bath and allow it to remain there until every vestige of the milky-white appearance has vanished. The negative can now be safely examined by white light. It must be thoroughly washed, as the hyposulphite of soda, if allowed to

remain in the film, will crystalize and destroy the negative. A negative washing box will be found to be of great assistance. Meanwhile rinse out the first tray and partially fill it with a solu-

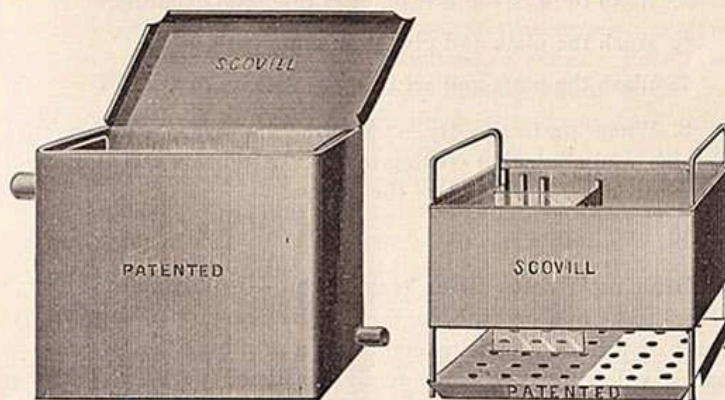

Negative Washing Box.

tion of 20 ounces of water and all the alum the water will hold in solution. Allow the plate to remain in the alum bath about five

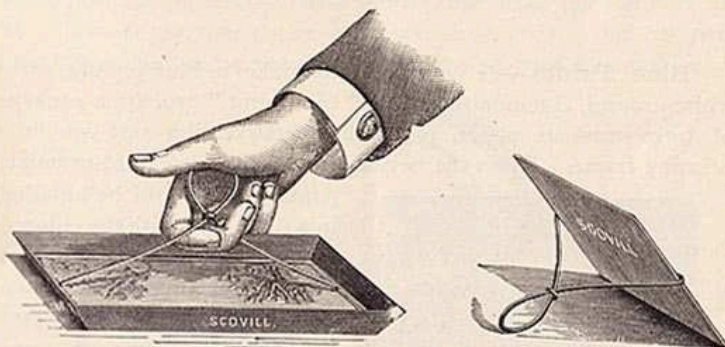

The Russell Negative Clasp.

minutes and then thoroughly wash it again and set it on edge to dry in a negative rack or the drying support.

All the preceding instructions can be briefly summarized as follows:

1. Put some sensitive plates into dry plate holders.
2. Make the exposures.
3. After taking a plate out of the holder, place it in a tray filled with water.

4. Drain off the water and pour over the plate the mixed developing solution.
5. Wash the plate and place it in the hypo. solution.
6. Wash the plate and give it an alum bath.
7. Wash the plate and set it in the rack to dry.
8. When perfectly dry, coat the film over with negative varnish, and allow that coating to dry. After this the surface of the plate may be touched by the fingers.

Making Prints from Negatives.—At this point the work ceases to be one of faith, as the results are now to appear. An outfit of printing requisites comprises a printing frame, a porcelain pan, a vulcanite tray, some ready sensitized paper, a bottle of French azotate, a bottle of chloride of gold, a glass graduate, some hyposulphite of soda, a glass form, a Robinson trimmer, some sheets of fine card-board, a jar of parlor paste, and a bristle brush.

Blue Prints.—If you wish to make a blue picture on a white ground, commonly called a "blue print," procure a package of ferro-prussiate paper, place the negative, film side up, in a printing frame. Upon the negative lay a piece of ferro-prussiate

paper (this should be handled in a dim light) with the colored side down. Close the back of the printing frame and fasten it by setting the springs. Carry the printing frame to some place where the sunlight will fall upon it, and from time to time examine the print. As soon as the picture is clearly seen, take out the print and throw it into a pan containing clean water. After about twenty minutes remove the print and dry it in the sunlight. The result is a permanent blue and white picture.

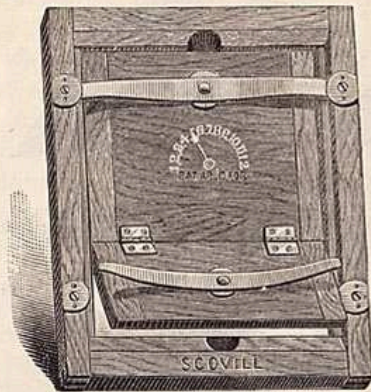

Scovill Printing Frame.

The result is a permanent blue and white picture.

which will at least answer for a proof and show the merit of your negative.

Sensitized Paper Prints.—In the morning prepare a toning bath sufficient for the prints to be toned that day. Put $7\frac{1}{2}$ grains of chloride of gold into $7\frac{1}{2}$ ounces of water. Label the bottle, "Chloride of Gold Solution." Take 1 ounce of French azotate, $1\frac{1}{2}$ ounces of the chloride of gold solution, and add 6 ounces of water, and you have a toning bath which keeps well. Where the prints do not give the required tone, the bath must be strengthened by adding to it some new solution. Place the glossy side of a sheet of sensitized paper upon the film side of the negative in the printing frame. *Do this in a very dim light.*

The printing has gone far enough when the print looks a little darker than you wish the finished picture to appear. Make as many prints from the negative as you desire. Wash the prints in several changes of water. Take seven ounces of the toning solution and change the prints to the pan containing it, where the prints should be turned over and over to make the toning even. The toning process should go on until the dark part of the pictures have a very faint purplish tint and the white portion is clear. Wash the picture, but preserve the toning solution. The pictures should now be left for twenty minutes in a solution composed of 4

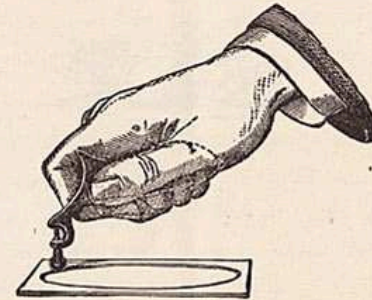

Robinson Trimmer.

ounces of hyposulphite of soda, 1 ounce of common salt, $\frac{1}{2}$ ounce of washing soda, and 32 ounces of water. This solution should also be prepared a day or two in advance. Give the pictures a final and effectual washing. After they are dried, lay them out one by one and, using the Robinson trimmer, cut them to the desired size. Now spread over the back of each

in turn some parlor paste, and lay them down with the center on the sheets of card-board. This operation is called "Mounting Pictures." Press with a paper cutter upon the pictures and toward their edges until you are satisfied that they will lay flat.

Further more explicit and complete instructions in the making of photographs, how they can be preserved in neat shape, instructions for making stereoscopic and instantaneous pictures, transparencies, magic lantern slides, and photographs of microscopic objects, are to be found in "How to Make Pictures," by Henry Clay Price (Fourth Edition.)



Old Style Equipment.

THE
SCOVILL
Portable
DRY PLATE OUTFITS
FOR AMATEURS



New Style Equipment.

THE introduction of Dry Plates and the impetus given by them to the cause of Amateur Photography, created a demand for light and compact apparatus that could be easily carried about. That demand the Scovill Manufacturing Company of New York *anticipated and first met* by the introduction of apparatus especially designed for the use of amateurs.

The Cameras they make for amateurs are not mere toys—they have been used and approved by eminent photographers. Certainly no apparatus can compare with that made by their American Optical Co.'s Factory, in durability, accuracy and elegance of finish. It is in use in all parts of the globe, and has by merit won this wide-spread reputation. Be not deceived by what is copied after it.

Every article enumerated in this Catalogue has the guarantee of the Scovill Manufacturing Co., established in 1802, and well known throughout the world for fair and honorable dealing as well as for the superiority of their photographic apparatus and specialties.

New Catalogues, circulars, etc., will be mailed to any one whose address is sent with the request for such copies.

SCOVILL'S Favorite Apparatus Outfits.

All Articles of which are Warranted Accurate in Every Respect.

These Outfits are lighter, more compact, far handsomer and more accurate than any which are offered at the same price. Many professional photographers have bought them and use them constantly.

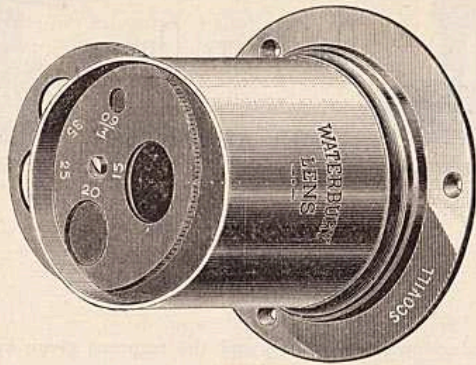

In each outfit the Waterbury Lens is worth more than the price of the whole outfit. Read description on page 41.

FAVORITE OUTFIT A, price \$10.00, comprises

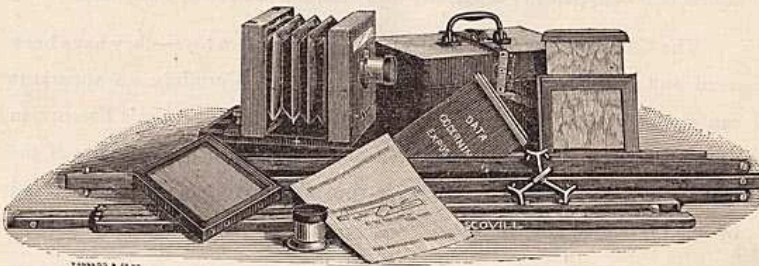

A FAVORITE VIEW CAMERA to produce 4x5 inch pictures, with *vertical shifting front, single swing movement*, rubber bellows and folding platform, with *patent latch* for making bed rigid instantaneously,

- 1 Scovill Double Dry Plate Holder (Reversible), with *patent Registering Slides*.
- 1 Taylor Improved Folding Tripod.
- 1 No. A "Waterbury" Achromatic Lens.
- 1 Carrying Case.

5 x 7 Favorite Outfit, - - - - Price, \$12.00

FAVORITE OUTFIT B, price \$12.00, comprises

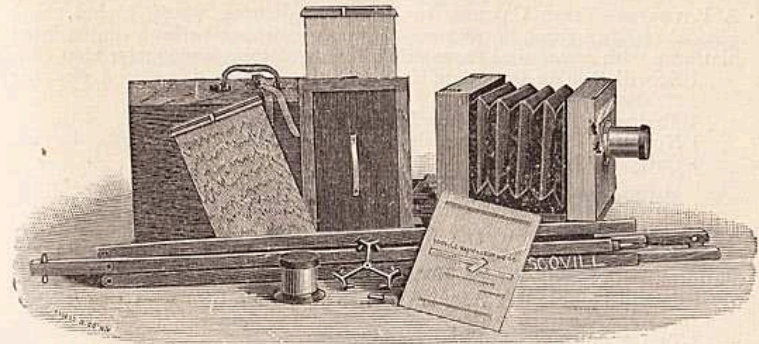

A FAVORITE VIEW CAMERA, to produce pictures 5x8 inches, with *vertical shifting front, single swing movement*, rubber bellows and folding platform, with *patent latch* for making bed rigid instantaneously; also

- 1 Scovill Double Dry Plate Holder (Reversible), with *patent Registering Slides, and with Kits*.
- 1 Taylor Improved Folding Tripod.
- 1 No. B "Waterbury" Achromatic Lens with *revolving diaphragms*.
- 1 Carrying Case.

FAVORITE OUTFIT C, price \$18.50, comprises

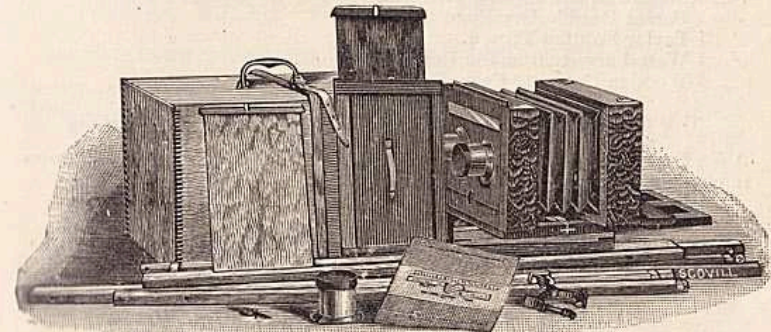

A FAVORITE VIEW CAMERA, to produce 5x8 inch pictures, with *vertical shifting front, single swing movement*, rubber bellows and folding platform, with *patent latch* for making bed rigid instantaneously.

This Camera is constructed so as to make either a *Picture* on the full size of the plate (5 x 8 inches), or by substituting the extra front (supplied with the outfit) and using the pair of lenses of shorter focus, it is admirably adapted for taking *stereoscopic* negatives. Included in this outfit are also

- 1 Scovill Double Dry Plate Holder (Reversible), with *patent Registering Slides, and with Kits*.
- 1 B "Waterbury" Achromatic Lens, with *revolving diaphragms*.
- 1 Pair "Waterbury" Achromatic Matched Stereoscopic Lenses.
- 1 Taylor Improved Folding Tripod.
- 1 Carrying Case.

FAVORITE OUTFIT D, price \$15.00, comprises

A FAVORITE VIEW CAMERA to produce pictures $6\frac{1}{2} \times 8\frac{1}{2}$ inches, with vertical shifting front, single swing movement, rubber bellows and folding platform, with patent latch for making bed rigid instantaneously; also

- 1 Scovill Double Dry Plate Holder (Reversible), with patent Registering Slides and with Kits.
- 1 Taylor Improved Folding Tripod.
- 1 No. BB "Waterbury" Achromatic Lens with Revolving Diaphragms.
- 1 Carrying Case.

FAVORITE OUTFIT E, price \$26.00, comprises

A FAVORITE VIEW CAMERA to produce pictures 8×10 inches, with vertical shifting front, single swing movement, rubber bellows and folding platform, with patent latch for making bed rigid instantaneously; also

- 1 Scovill Double Dry Plate Holder (Reversible), with patent Registering Slides, and with Kits.
- 1 Taylor Improved Folding Tripod.
- 1 No. C "Waterbury" Achromatic Lens with revolving diaphragms.
- 1 Carrying Case.

SCOVILL'S NE PLUS ULTRA OUTFITS.

4 x 5 Ne Plus Ultra Outfit, price \$9.00, comprises

A 4 x 5 Ne Plus Ultra Camera, which has single swing, rubber bellows, removable front and folding platform.

- 1 Patent Double Dry Plate Holder.
- 1 Taylor Folding Tripod.
- 1 Waterbury Achromatic Lens with Stops.
- 1 Wooden Carrying Case.

5 x 8 Ne Plus Ultra Outfit, price \$10.00, comprises

A 5 x 8 Ne Plus Ultra Camera, which has single swing, rubber bellows, removable front and folding platform.

- 1 Patent Double Dry Plate Holder.
- 1 Taylor Folding Tripod.
- 1 Waterbury Achromatic Lens with Revolving Diaphragms.
- 1 Wooden Carrying Case.

 $6\frac{1}{2} \times 8\frac{1}{2}$ Ne Plus Ultra Outfit, \$14.00.**EQUIPMENT A-A.**

Consists of FAVORITE APPARATUS OUTFIT A, with

- 1 Scovill Focusing Cloth.
- 1 Dozen 4 x 5 Dry Plates.
- 1 W. I. A. Petite Lantern.

Complete for field service, Price, \$12.00.

EQUIPMENT B-B.

Consists of FAVORITE APPARATUS OUTFIT B, with the additional articles enumerated in A-A. (Dry Plates 5 x 8 size.)

Complete for field service, Price, \$14.50.

EQUIPMENT C-C.

Consisting of FAVORITE APPARATUS OUTFIT C, with the additional articles mentioned in Equipment A-A. (Dry Plates 5 x 8 size.)
Complete for field service, Price, \$21.00.

EQUIPMENT D-D.

Consisting of FAVORITE APPARATUS OUTFIT D, with the additional articles enumerated in A-A. (Dry Plates $6\frac{1}{2} \times 8\frac{1}{2}$ inches.) Price, \$18.00.

Where sensitive Plates are taken to a photographer's and there developed, printed from, and mounted on card-board, any of the above Equipments lack nothing that is essential. We recommend the amateur to finish his own pictures, and hence to procure one of the equipments on page 15.

EQUIPMENT A-A-A.—Price, \$20.00.

Complete in every Requisite for making the Highest Class Pictures.

LACKING NOTHING FOR VIEW TAKING, DEVELOPMENT AND THE PRINTING AND MOUNTING OF PHOTOGRAPHS.

Consisting of Favorite Apparatus Outfit A.....\$10 00
Also 1 Developing Outfit 4 x 5 (see page 14)..... 5 25
" 1 Printing and Toning Outfit, 4 x 5 (see page 15)..... 4 87

EQUIPMENT B-B-B.—Price, \$24.50.

Complete in every Requisite for making the Highest Class Pictures.

Consisting of Favorite Apparatus Outfit B.....\$12 00
Also 1 Developing Outfit 5 x 8 (see page 14)..... 6 50
" 1 Printing and Toning Outfit 5 x 8 (see page 15)..... 6 88

EQUIPMENT C-C-C.—Price, \$31.00.

Complete in every Requisite for making the Highest Class Pictures.

Consisting of Favorite Apparatus Outfit C.....\$18 50
Also 1 Developing Outfit 5 x 8 (see page 14)..... 6 50
" 1 Printing and Toning Outfit 5 x 8 (see page 15)..... 6 38

EQUIPMENT D-D-D.—Price, \$29.00.

Consisting of Favorite Apparatus Outfit D.....\$15 00
Also 1 Developing Outfit $6\frac{1}{2} \times 8\frac{1}{2}$ (see page 14)..... 7 00
" 1 Printing and Toning Outfit $6\frac{1}{2} \times 8\frac{1}{2}$ (see page 15)..... 7 00

EQUIPMENT E-E-E.—Price, \$42.00.

Consisting of Favorite Apparatus Outfit E.....\$26 00
Also 1 Developing Outfit 8 x 10 (see page 14)..... 8 50
" 1 Printing and Toning Outfit (see page 15)..... 8 50

SCOVILL'S

Pure Chemicals & Accessories

FOR MAKING NEGATIVES.



We offer for use with any Outfit to make pictures 4 x 5 inches, the following goods packed securely in a wooden case:

- | | |
|---|---|
| 1 pkg. S.P.C. Carbonate Soda Developer,
2 4 x 5 Glossy Rubber Pans,
1 4 oz. Graduate,
1 Minum Graduate,
1 oz. Bromide Ammonium,
1 lb. Hyposulphite Soda, | 1 lb. Alum,
1 bot. S.P.C. Negative Varnish,
1 doz. 4 x 5 Dry Plates,
1 Scovill Focusing Cloth,
1 Knock-down Lantern,
1 Russell Negative Clasp. |
|---|---|

PRICE, COMPLETE, \$5.25.

For use with any 5x8 Outfit we supply the same goods, with the exception of the substitution of 5x8 Pans and Plates for the 4x5 size.

PRICE, 5x8 DEVELOPING OUTFIT, \$6.50.

- | | | |
|---------|---|---------|
| “ 6½x8½ | “ | “ 7.00. |
| “ 8x10 | “ | “ 8.50. |

S. P. C.

Outfit for Printing, Toning, Fixing and Mounting 4 x 5 Pictures.

- | | | |
|---|-------------------------|---|
| 1 4 x 5 Printing Frame.
1 5 x 7 Porcelain Pan, Deep.
1 4½ x 5½ S. P. C. Vulcanite Tray.
3 dozen 4 x 5 S. P. C. Sensitized Albumen Paper.
1 bottle French Azotate. } For
1 " Chlor. Gold, 7½ gr. } toning.
1 2 ounce graduate. | Price complete, \$4.87. | 1 lb. Hyposulphite of Soda.
2 dozen sheets 6½ x 8½ Card-board with Gilt Form.
1 ½ Pint Jar Parlor Paste.
1 1½ inch Bristle Brush.
1 Glass Form (for trimming prints).
1 Robinson's Straight Trimmer. |
|---|-------------------------|---|

Securely packed in a box, which serves also for a fuming box.



S. P. C.

Outfit for Printing, Toning, Fixing and Mounting 5 x 8 Pictures.

This outfit is like the one on preceding page, but with Printing Frame, Vulcanite Tray, Sensitized Paper, and Card-board adapted for 5 x 8 Pictures.

Price complete, \$6.38. Securely packed in a Paper Box.

- | | | |
|-------------------------------------|--------|---------|
| 6½ x 8½ Printing and Toning Outfit. | Price, | \$7.00. |
| 8 x 10 " " " " | | 8.50. |

THE SCOVILL
A. B. C.
Photographic : Outfits



INCLUDING

Landscape Lens, Dry Plates,
Developing AND Printing Materials,
AND ALL NECESSARY REQUISITES FOR MAKING A FIN-
ISHED, MOUNTED "BLUE" PRINTED PHOTOGRAPH.

The complete A. B. C. Photographic Outfit consists of view camera for making $3\frac{1}{4} \times 4\frac{3}{8}$ pictures, with a quick-working lens; 6 rapid dry-plates; 2 japanned iron trays; 2 packages of S. P. C. developer (Nos. 1 and 2); a package of hypo; 1 printing frame; half dozen sheets ferro-prussiate paper; half dozen card mounts; 1 sheet of ruby paper, with full instructions for lighting the dark-room and constructing a ruby lamp; 1 Russel negative clasp and patent drying frame.

No. 1—Price, complete.....\$2 50
No. 2—Price, complete, with toning solutions and paper added to its outfit for making silver prints..... 3 00

THE AMERICAN
Scholars' Complete Outfit.

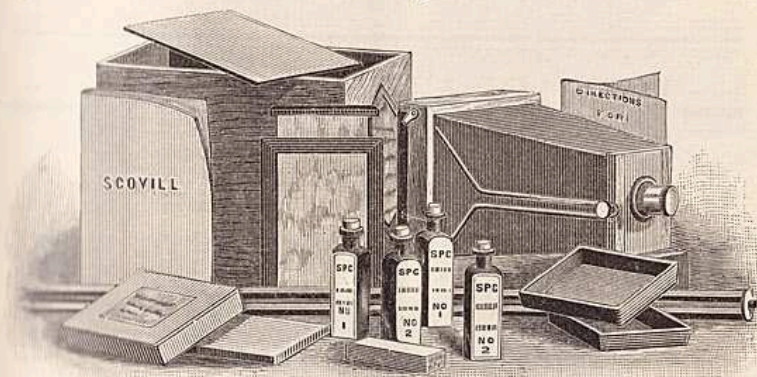

No. 1 SCHOLARS' OUTFIT,
CONSISTING OF

- 1— $4\frac{1}{4} \times 5\frac{1}{2}$ Camera, fitted with
 - 1— $4\frac{1}{4} \times 5\frac{1}{2}$ Dry Plate Holder,
 - 1—Single Achromatic Lens and
 - 1—Tripod;
 - 1—doz. $4\frac{1}{4} \times 5\frac{1}{2}$ Gelatine Dry Plates,
 - 2— $4\frac{1}{4} \times 5\frac{1}{2}$ Japanned Trays,
 - 1—3 oz. bottle S. P. C. Pyro and Potash Developing Solution, No. 1.
 - 1—3 oz. bottle S. P. C. Pyro and Potash Developing Solution, No. 2.
 - 1—6 oz. package of Hyposulphite of Soda,
 - 1—package 4×5 S. P. C. Ready Sensitized Albumen Paper,
 - 1—3 oz. bottle S. P. C. Toning Solution No. 1,
 - 1—3 oz. " " " " No. 2,
 - 1—sheet of yellow Post Paper, and
- Full directions for making Photographs with the above, packed securely in a neat wooden box.

Price, \$5.00.

No. 2 Scholars' Outfit comprises same apparatus, materials, etc., as above, but of size suitable for $3\frac{1}{4} \times 4\frac{1}{4}$ photographs.

PRICE, \$4.50.

NEW YORK

DRY PLATE OUTFITS

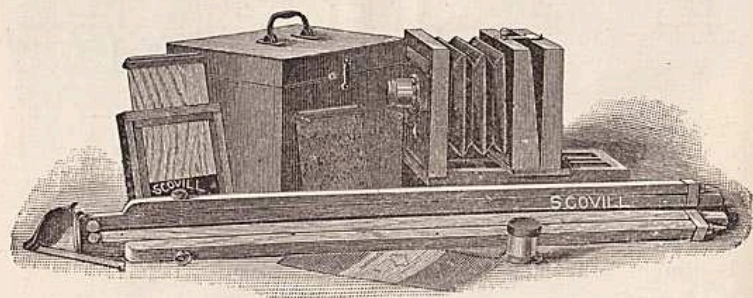

These outfits are unsurpassed in neatness, lightness, and compactness, and there is no question about their durability. Each one is supplied with a patent reversing attachment, which has been styled "the lightning reverser."

New York Outfit 601, size $4\frac{1}{4} \times 5\frac{1}{2}$, consisting of

- 1 Finely Finished Single Swing Camera, with Folding Bed and Improved Dry Plate Holder.
- 1 No. 1 Extension Tripod, with Patent Reversing Attachment.
- 1 No. A Waterbury Lens, with a set of Stops, and
- 1 Compact Carrying Case, with Handle. Price, \$10.00.

New York Outfit 603, size $6\frac{1}{2} \times 8\frac{1}{2}$, same as described above, except in respect to size. Price, \$14.00.

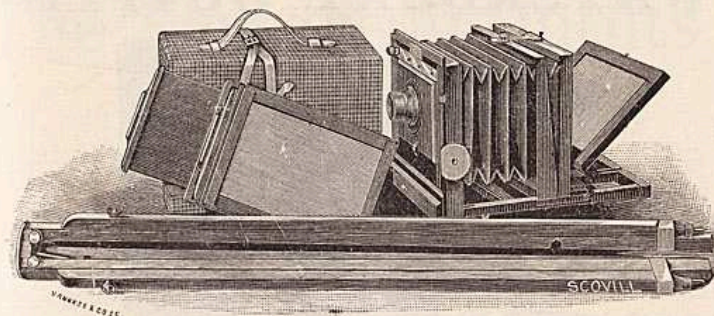

THE 1888 INSTANTANEOUS OUTFIT

is of the very highest class made by the AMERICAN OPTICAL Co. It is very compact and light, and is offered 25 per cent. below what the separate parts cost.

It consists of a MAHOGANY POLISHED CAMERA for taking pictures 4 x 5 inches, with *Folding Bellows Body*, single swing, hinged platform, and brass guides. It has also a shifting front for adjusting the sky and foreground. Fitted with

One Double Dry Plate Holder, with *Patent Registering Slides*; also

One Canvas Carrying Case.

One No. 1 Scovill Adjustable Tripod.

One Optimus Lens, price \$20.00; and

One Scovill Universal Shutter, with Pneumatic, Time, and Instantaneous Attachments, price, \$5.00.

Total, **\$47.00.**

1888 Instantaneous Outfit, when sold complete, \$35.00.

WATERBURY OUTFITS.

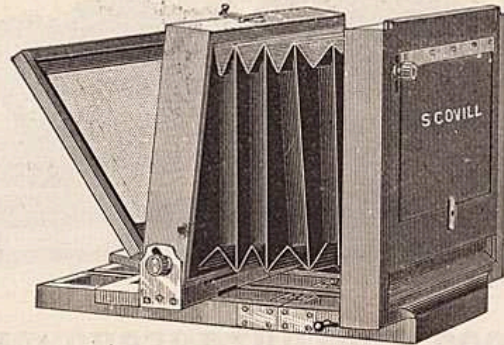

THE WATERBURY CAMERAS, introduced in 1885, are like other cameras and apparatus made by the American Optical Company—unapproachable!

They are made of mahogany, are well polished, have rubber bellows, folding platform, *patent latch* for making bed rigid instantaneously, single swing, vertical shifting front, and are as light and compact as substantial cameras can be constructed.

Fitted with
Eastman-Walker
Roll-Holder.
1887 Model,
with
Automatic Tally

4x5 Waterbury Outfits, Complete.....\$12 00 22 00

CONSISTING OF

- 1 Single Swing Camera, described above.
- 1 Scovill Double Dry Holder, with *Patent Registering Slides*.
- 1 Wooden Carrying Case.
- 1 Improved Taylor Tripod.
- 1 No. A Waterbury Lens with a set of Stops.

LATEST SIZES INTRODUCED	{	4½x5½ Waterbury Outfit, complete	\$14 00
		4½x6½ " " "	15 00
		5x7 " " "	16 00

5x8 Waterbury Outfits, Complete.....\$16 50 29 00

CONSISTING OF

- 1 Single Swing Camera, described above.
- 1 Scovill Double Dry Holder, with *Patent Registering Slides*.
- 1 Wooden Carrying Case.
- 1 Improved Taylor Tripod.
- 1 No. B Waterbury Lens with revolving diaphragm.

5 x 8 Waterbury Stereoscopic Outfit.

With one B and a matched pair of A Waterbury Lenses,

Price, complete, \$23.00.

6½x8½ Waterbury Outfits, Complete....\$21 00 37 00

CONSISTING OF

- 1 Single Swing Camera, described above.
- 1 Scovill Double Dry Holder, with *Patent Registering Slides*.
- 1 Wooden Carrying Case
- 1 Improved Taylor Tripod.
- 1 No. B Waterbury Lens with revolving diaphragm.

The Flandreau Outfits.

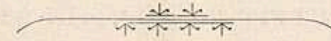

LIKE everything else which bears this name, the Flandreau Camera is excellent in every respect. Made in two sizes (4x5 and 5x7), it folds up in so compact a form that the smaller size may almost be packed in a large overcoat pocket. It is eminently the tourist's and outdoor photographer's camera. In fact it embodies many of the advantages of Scovill's Old Tourist Camera, with much that is new and improved. The rods which are used to move forward the front of the camera are nicely adjusted, and are polished and nickel-plated, so that they add to the handsome appearance of the camera, and contrast well with its polished mahogany surface and the dark hue of its bellows. In addition to this portable arrangement, the Flandreau box is reversible, has a liberal swing back and front and rising front board. The bellows is cone shaped, and focuses by the forward movement. When closed for carrying the bed becomes a closing front board which is firmly secured at the top by a spring. The tripod head is fastened to this board so that, in adjusting, all that is necessary is merely to lower the front and fasten the tripod legs to the top, which is already secured beneath the board. The swing is held in any position by a new and very clever device. The ground glass is hinged, as in English cameras, to throw over the top of the instrument. Altogether this is one of the finest finished cameras which has ever emanated even from the works of the American Optical Company.

4x5 Flandreau Outfit consists of 4x5 Flandreau Camera, with
1 Daisy Double Dry Plate Holder, with *Patent Registering Slides*.
1 Scovill Adjustable Tripod No. 1.
1 Canvas Carrying Case.

Price, complete, \$24.00.

5x7 Flandreau Outfit consists of 5x7 Flandreau Camera, with
1 Daisy Double Dry Plate Holder, with *Patent Registering Slides*.
1 Scovill Adjustable Tripod No. 2.
1 Canvas Carrying Case.

Price, complete, \$32.00.

We recommend the purchase and use with the above Outfits of a Lens or Lenses selected from the list on page 42.

For Developing and Printing Outfits to be used with the above, refer to pages 14 and 15.

Centennial Outfits.

(Introduced in 1876.)

CENTENNIAL OUTFIT No. 202, price \$22.00, Consists of

A MAHOGANY POLISHED CAMERA for taking pictures 4 x 5 inches, with *Folding Bellows Body*, single swing, hinged bed, and brass guides. It has a shifting front for adjusting the sky and foreground, with
 1 Daisy Double Dry Plate Holder, with *Patent Registering Slides*; also
 1 Canvas Carrying Case.
 1 No. 1 Scovill Adjustable Tripod.

CENTENNIAL OUTFIT No. 202 A, price \$24.00,

The same as No. 202, but with Camera for taking pictures 4½ x 5½ inches.

CENTENNIAL OUTFIT No. 202 B, price \$26.00, for pictures 4½ x 6½ inches.

CENTENNIAL OUTFIT No. 203, price \$30.00, Consists of

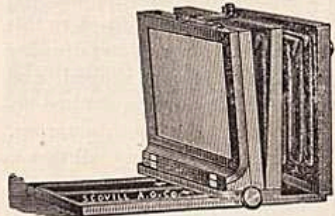

A FOLDING MAHOGANY CAMERA, well known as the '76 Camera (see illustration). It is adapted for taking 5 x 8 inch pictures, and also for stereoscopic views—together with

1 Daisy Double Dry Plate Holder, with *Patent Registering Slides*; also
 1 Canvas Carrying Case.
 1 No. 2 Scovill Adjustable Tripod.

CENTENNIAL OUTFIT No. 204, price \$42.00, Consists of

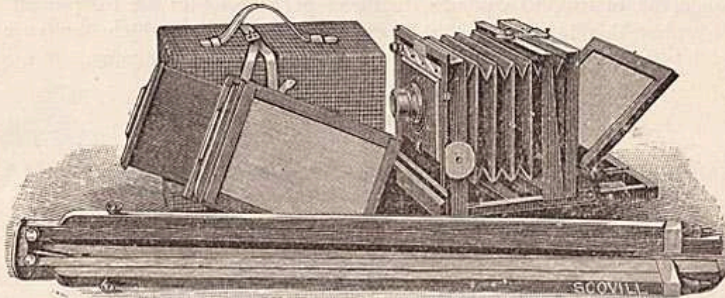

A FOLDING MAHOGANY CAMERA of finest style and finish for taking 6½ x 8½ inch pictures, with

1 Daisy Dry Plate Holder, with *Patent Registering Slides*; also
 1 Canvas Carrying Case.
 1 Scovill Extension Tripod, No. 3.

For larger or special View Cameras, consult the American Optical Company's Catalogue.

We recommend the purchase and use with the above Outfits of a Lens or Lenses selected from the list on page 42.

For Developing and Sensitized Paper Outfits to be used with the above refer to pages 14 and 15.

Albion Cameras.



THE following illustrations and description are given to assist in determining the choice of those who want a camera that is "quite English, you know."

TURN-TABLE.

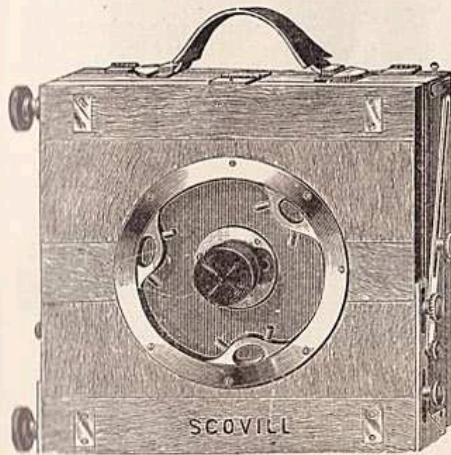

ALBION CAMERA OUT OF CASE (FOLDED).

The Albion Cameras are provided with the Scovill turn-table, whose excellence is due, not only to the fact that it has an open center into which the lens projects, thus doing away with the necessity of unscrewing the lens every time the front board of the camera is turned down in order to fold the camera, but what is of equal importance, the bearings of the turn-table are so nicely adjusted, that

they do not become clogged at any time—a defect in all imported cameras. There is also no need of a regulator or fastener for this turn-table. In whatever direction the camera is turned it remains until moved by the photographer. The extreme accuracy and nicety of the working of the Scovill turn-table can only be fairly appreciated when tried.

COMPACTNESS. Before passing from the Scovill turn-table, it is well to bear in mind that serving as a tripod top, it does away with the necessity of any other, and the bothersome tripod screw. In the highest degree, compatible with the requisite strength, the Albion Camera is compact and portable.

CARRYING CASE.



CANVAS BAG FOR ALBION CAMERA.

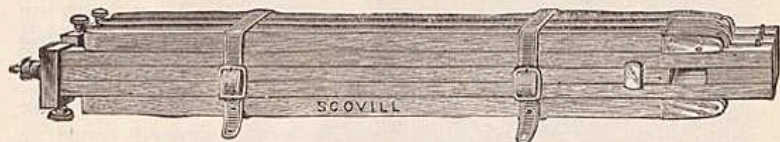

ALBION TRIPOD.

ALBION TRIPOD. While folding compactly, as here shown, the Albion Tripod is readily extended and firm enough to support, without vibration, a 10x12 view camera. The binding straps are attached to one of the legs, so that they are always there when wanted.

The Albion Camera has the Howe patent reversible back, is arranged for double swing and a single swing front, and, when used with the SHIFTING FRONT, the extreme possibility of tilting is attained. The tallest towers must come down to the ground-glass screen, which, in common with all cameras of the English pattern, is hinged so that it may throw over the top of the camera or behind the holder when that is in use.

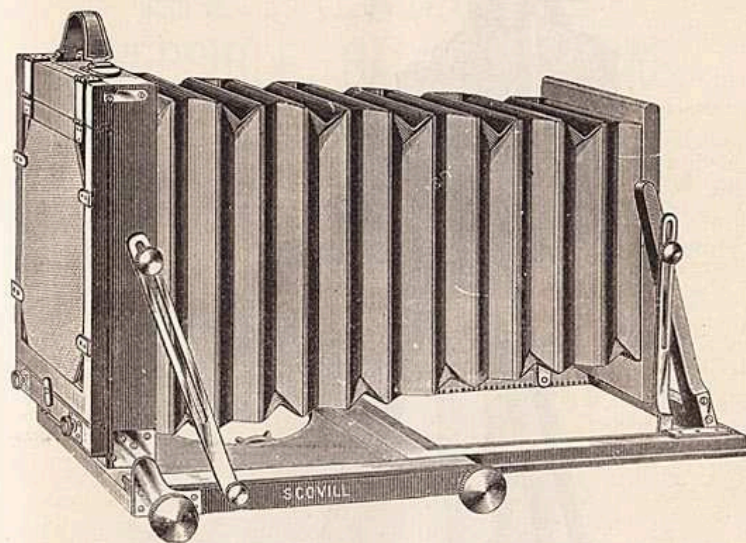

ALBION CAMERA EXTENDED.

The cut showing the Albion Camera partly folded, and the one showing the great length of platform when the extension bed is fully drawn out, really make extended comment unnecessary, but it will not do to pass by so lightly the DOUBLE PLATE HOLDERS fitted to the Albion Camera. All of the imported English holders (double backs, "you know"), warp when subjected to the severe test of our climate, and the slides refuse, without provocation, to move.

We have not or do not propose to imitate them, but fit the Albion Cameras with double holders, which we guarantee not to warp, and we put in them our patent Registering (Record) Slides.

The marked superiority of the Albion Cameras over any and all styles of English make will be more apparent on examination, or, better still, through using one of them.

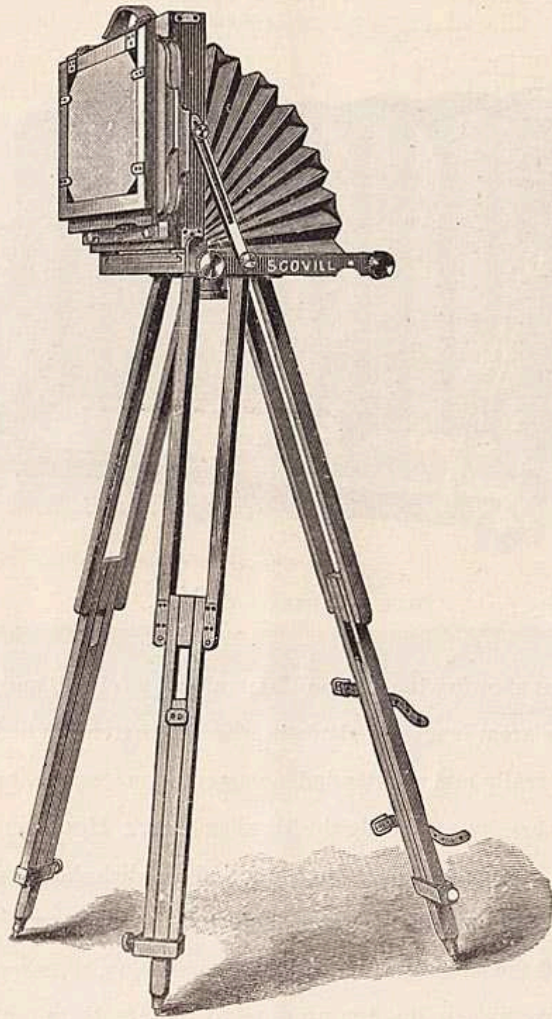

ALBION CAMERA AND TRIPOD.

PRICE-LIST OF ALBION CAMERAS.

Each with Albion Tripod and Extra Fine Canvas Carrying Case.

No.	Size	Price	Price with 1887 Model Roll Holder.
No. 560	4 3/4 x 6 1/2	\$47 00	\$61 50
" 561	5 x 7	48 00	62 50
" 562	5 x 8	49 00	67 00
" 563	6 1/2 x 8 1/2	50 00	68 00
" 562	8 x 10	60 00	82 00

ST. LOUIS REVERSIBLE BACK CAMERAS.

(PATENTED.)

In addition to the desirable features which the Back Focus Reversible Camera possesses (see description below) the St. Louis Reversible-Back Cameras have the rack and pinion movement, *patent latch* for making the bed rigid instantaneously, and the ground-glass so arranged that the holder may be slid in front of it, as shown in the illustration.

Each Camera is supplied with one Daisy Holder with *patent Registering Slides* and canvas case.

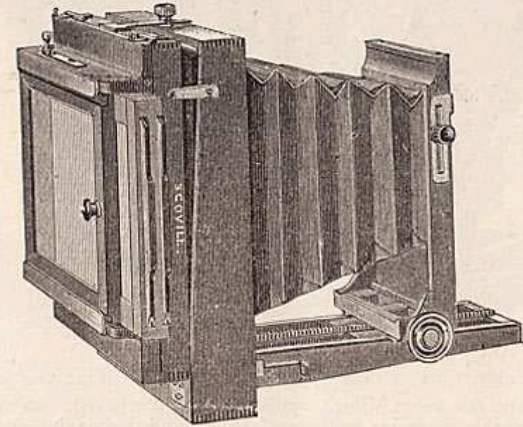

The growing use of dry plates, and the desire for rapid exposures, led to the introduction of the American Optical Patented Reversible Back Cameras, and because they add to the grace and celerity of view-taking they have become vastly popular. A novel arrangement of a detachable carriage at the back combines such a multiplicity of adjustments in itself that a dry-plate holder may be reversed or be set for either an 8x10 upright or horizontal picture—all of these movements, without once changing the dry-plate holder in the carriage.

ST. LOUIS REVERSIBLE-BACK CAMERAS.

Fitted with Eastman-Walker Roll Holder.
1887 Model.

No.	For View.	Single Swing-back.	Double Swing-back.	Single Swing-back.	Double Swing-back.
No. 110	4 x 5	\$25 00	\$29 00	\$35 00	\$39 00
" 111	4 1/4 x 5 1/2	26 00	30 00	36 00	40 00
" 112	4 1/4 x 6 1/2	30 00	34 00	40 00	44 00
" 113	5 x 7	32 00	35 00	44 50	47 50
" 114	5 x 8	34 00	38 00	46 50	50 50
" 115	6 1/2 x 8 1/2	36 00	40 00	52 00	56 00
" 116	8 x 10	40 00	44 00	60 00	64 00
" 117	11 x 14	60 00	64 00	90 00	94 00

Not made above 11x14 size.

For automatic tally on Roll Holder add \$5.00.

Canvas cases to contain Camera with more than one Holder made to order at extra price.

Flammang's Patent Revolving-Back Cameras.

(PATENTED.)

Each Incased in a Canvas Bag, with Handle.

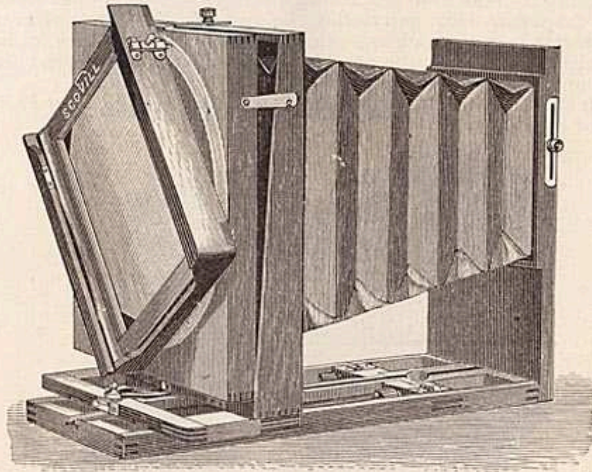

(BACK FOCUS PATTERN.)

"These are the finest View Cameras ever constructed," so says every photographer who has examined any of them, and this exclamation is not merely a tribute to the beauty and grace of their design, for invariably the desire has at the same time been expressed to possess one of these truly novel and substantial Cameras.

Wherein lies the merit and attractiveness of the Revolving-Back Camera, that photographers want to cast aside cameras now in use and procure one of this new pattern? Briefly stated, it enables the view taker to secure either an upright or a horizontal picture without changing the plate holder after it has been slid into the carriage. No other camera can with such wondrous ease and celerity be changed from the vertical to the upright or *vice versa*. The carriage is simply turned about in the circle and automatically fastened. By this latter provision the carriage may be secured at either quarter of the circle. Ordinarily, the slide will be drawn out of the holder to the right; but in certain confined situations, the ability to withdraw the slide to the left enables the photographer to obtain a view which he could not get with the usual provision in a camera. The photographer of experience is well aware of the difficulty, when taking an upright picture with a large camera without the revolving back feature, of reaching up to draw out the slide at the top, and, what is more essential, of getting out the slide without fogging the plate in the holder.

Grace and strength are combined in the Revolving-Back Camera, and its highly-desirable features are gained without the sacrifice of steadiness or any other essential principle in a good camera. Indeed, its merit is such that out-door photography has been advanced and made more attractive by its introduction.

Revolving-back Camera.

(PATENTED.)

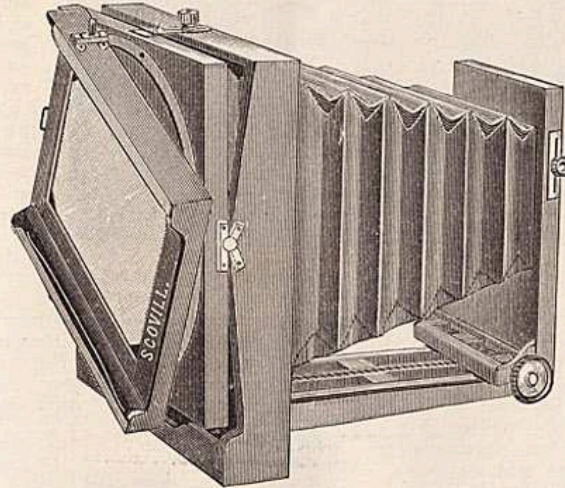

(FRONT FOCUS PATTERN.)

REDUCED PRICE LIST.

Revolving-back Cameras, each incased in a canvas bag, with handle, and above 14x17 size, with two handles.

No.	REVERSIBLE.	Single Swing.	Double Swing.	With Reversible Back and Holder Extra
No. 120.	For View 4 x 5 in.	\$27 00	\$32 00	
" 121.	4 1/4 x 5 1/2 "	29 00	34 00	
" 122.	4 1/4 x 6 1/2 "	31 00	36 00	
" 123.	5 x 7 "	33 00	38 00	
" 124.	5 x 8 "	35 00	40 00	
" 125.	6 1/2 x 8 1/2 "	40 00	45 00	
" 126.	8 x 10 "	45 00	50 00	
" 127.	10 x 12 " detachable back.	60 00	65 00	
" 128.	11 x 14 "	65 00	70 00	
" 129.	14 x 17 "	75 00	80 00	\$90 00
" 130.	17 x 20 "	85 00	90 00
" 131.	18 x 22 "	95 00	100 00	105 00
" 132.	18 x 22 "	115 00
" 132.	20 x 24 "	115 00	120 00	130 00
" 133.	25 x 30 "	150 00

These Cameras are fitted with Daisy Dry-plate Holders.

Please state, when ordering any size below 10x12, whether front or back focus is desired.

Revolving-back Cameras, front focus, not made above 8x10 size.

Canvas cases to contain Camera with more than one Holder made to order at extra price.

THE SCOVILL MANIFOLD CAMERA.

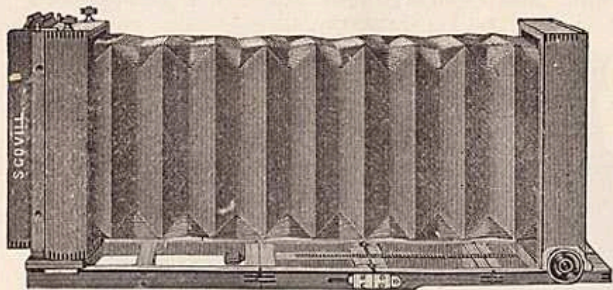

While this camera serves manifold purposes as its name indicates, nothing could be more simple or more easily manipulated. The Manifold Camera has

special advantages peculiar to itself and possesses the greatest number of desirable features which can be combined in a camera without sacrificing lightness and compactness, or having complicated adjustments. The unique device which controls the horizontal and vertical swings was patented by Mr. W. J. Stillman, of the editorial staff of the PHOTOGRAPHIC TIMES. To this has been added a central latch for the purpose of bringing the swing movements within perfect control of the operator. An approximate focus is obtained quickly

with the rear portion of the camera, which is provided with the patent reversible back. The fine focus is obtained by means of the rack and pinion movement, shifting the front upon which the lens is attached.

While this camera is made to compass the great length of draw shown in

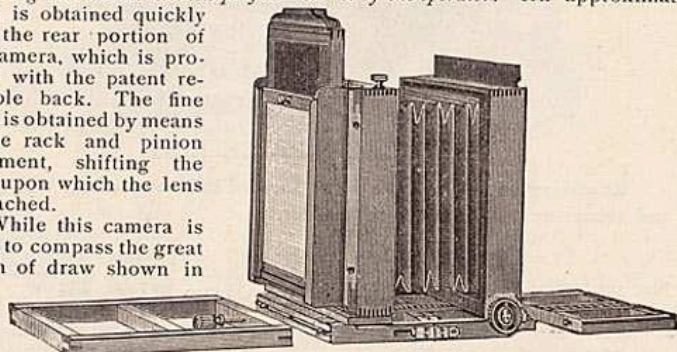

the first illustration, the rear portion of the bed may be wholly detached, and when desired, one-third of the remaining portion of the platform; a great advantage when photographing interiors, when an obtrusive tail board renders focusing almost an impossibility. With one-half of the bed taken off, this camera is still of the usual length of draw. The ground glass, when not in use, is displaced, not detached, by having the plate holder slid in front of it. This arrangement of ground glass and plate holder is shown in the second view. Still another noticeable feature is the absence of clamping screws from the front boards, to move which one needs but to press firmly against the lens. The bed folds in front of and behind the camera, and has the patented latch recently devised at the American Optical Co.'s factory. PRICE LIST, including Canvas Case for Camera and one Holder, with patent Reg. Slides.

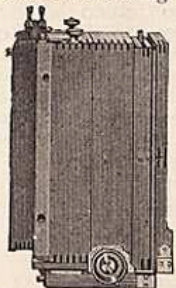

No.	No.	No.
140. 3¼x4¼ size \$30 00	143. 4¾x6½ size \$38 00	145. 6¼x8½ size \$45 00
141. 4x5 size... 32 00	144. 5x7 size... 38 00	146. 8x10 size... 50 00
142. 4¼x5½ size 34 00		

PRICE LIST

—:) OF (—

Scovill Detective and Concealed Cameras.



THE VERY Latest Detective Camera.

(PATENT APPLIED FOR.)

(SEE ILLUSTRATION ON PAGE 31.)

THE Waterbury Detective Cameras having proved to be so popular, we have concluded to introduce **Detective Cameras** of this style, fitted with Roll-Holder instead of Double Dry-Plate Holder. This new Camera has the Automatic Tally, without which no Roll-Holder is complete, and is very compact and light, weighing but a little over three pounds.

Every Waterbury Detective Camera is fitted with a Wale Instantaneous Lens, has a recessed Finder, and a Tripod Plate for use with a Tripod. It has a Cap, and is perfectly adapted for timed as well as instantaneous exposures.

4 x 5 Waterbury Detective Camera, with 2 Double Holders,	\$25.00
5 x 7 " " " " 2 " "	50.00
4 x 5 " " " " Roll-Holder and Auto- matic Register, - - - - -	35.00
5 x 7 Waterbury Detective Camera, with Roll-Holder and Auto- matic Register, - - - - -	68.00

It has not come to be generally known, but such is the fact, that Artists of renown, and shrewd Detectives, carry our Detective Cameras, and pictures are secured by them for their different lines of study, through their instrumentality, in a manner which is perfectly simple—in fact, it requires no skill other than to get within the range of focus of the unsuspecting victim. As the the party, whether man, woman, or child, is not aware that anything unusual is transpiring, the expression of the countenance and the pose are not arranged with reference to their appearance in a picture. A quick-working lens is hidden in the camera, and also a few plate holders. By pressing on a spring the whole operation of exposure is completed.

ANY Amateurs have declared that the pleasure of picture taking was not fully revealed to them until they had procured and tried one of the

SCOVILL DETECTIVE CAMERAS.

(PATENTED.)

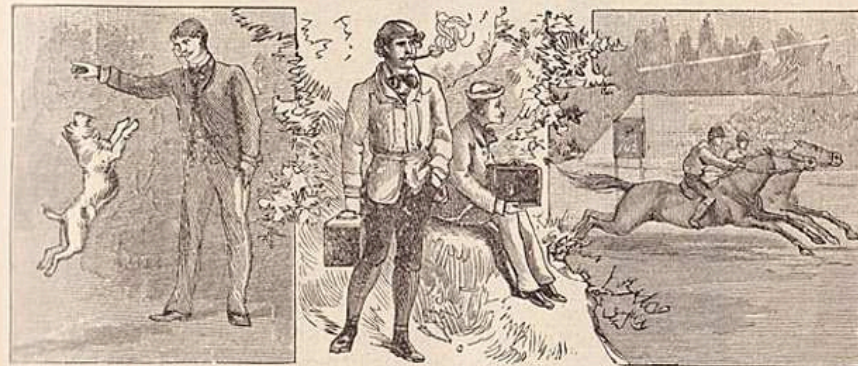

SWING BACK.—In answer to the popular demand, a swing back has been devised for the SCOVILL DETECTIVE CAMERAS, which is simple and effective. It is readily adjusted from the bottom of the case, where all of the outward mechanism of this instrument is placed.

PATENTED ADAPTER FOR TWO LENSES.—This device enables one to use interchangeably at pleasure, by simply moving the focusing lever a wide angle, and also a group lens of quite dissimilar focus. This does away with the necessity of unscrewing the flange of one lens in order to put on the flange belonging to the other lens.

	With Swing Back.	With Swing back; also with adapter & Morrison wide angle lens.
Scovill's Detective Camera, for 3½x4½ pictures with Morrison Lens and three double Dry-plate Holders.....	\$50 00	\$55 00
Scovill's Detective Camera, for 4x5 pictures, with Morrison Lens and three double Dry-plate Holders.....	60 00	65 00
4¼x6½ Detective Camera, with Ross Lens and three double Dry-plate Holders.....	90 00	95 00
4¾x6½ Detective Camera, with Ross Lens and three double Dry-plate Holders.....	95 00	100 00
5 x 7 Detective Camera, with Ross Lens and three double Dry-plate Holders.....	100 00	105 00

ROLL-HOLDER DETECTIVE CAMERAS.

It followed naturally upon the introduction of the Roll Holder that it should be applied to the SCOVILL DETECTIVE CAMERA, and this has been done in a manner that displays the greatest ingenuity.

Attached to each is the Patent Automatic Tally, to record the number of exposures made. No Roll Holder Camera is complete without this.

Scovill's Roll Holder Detective Camera, for 3½x4½ Pictures, with the marvelous Optimus Lens, Roll Holder, with Automatic Tally, and one double Dry-plate Holder.....	65 00	105 00
Scovill's Roll Holder Detective Camera, for 4x5 Pictures, with the marvelous Optimus Lens, Holder Roll, with Automatic Tally, and one		

CONCEALED CAMERAS.

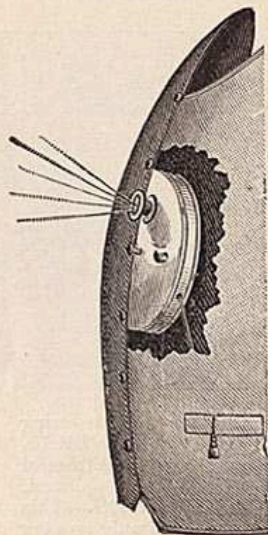

The **Concealed Cameras** are designed for the use of those who wish to photograph, without attracting the attention of any one, the interesting sights met in every-day life, such as picturesque groups, quaint figures, and striking facial expression, where opportunity to sketch or to set up an ordinary camera and tripod, arrange the focus, draw slides, and such manipulation are out of the question. The beautiful results obtained with this Camera, and the ease with which they are secured, make it of great value to artists and detectives.

The **New (No. 2) Concealed Camera** was planned to make pictures of the size suitable for lantern slides. A handsome velvet-lined leather

case is provided with it in which the Camera is carried or used when it is not worn underneath the vest.

CONCEALED CAMERAS.

No. 1, in Sliding Cover Box.....	\$15 00
Keystone Plates.....	1 20
Film Carriers.....	50
American Films, in two-dozen packages.....	1 75
Skins, in two-dozen packages.....	38
No. 2, for Lantern Slides, in Velvet-Lined Leather Case.....	25 00
Keystone Plates.....	1 65
Film Carriers.....	75
American Films, in two-dozen packages.....	2 55
Skins, in two-dozen packages.....	50

SAMPLE PHOTOGRAPHS FURNISHED.

POCKET Photographic Outfits for Bicyclists.

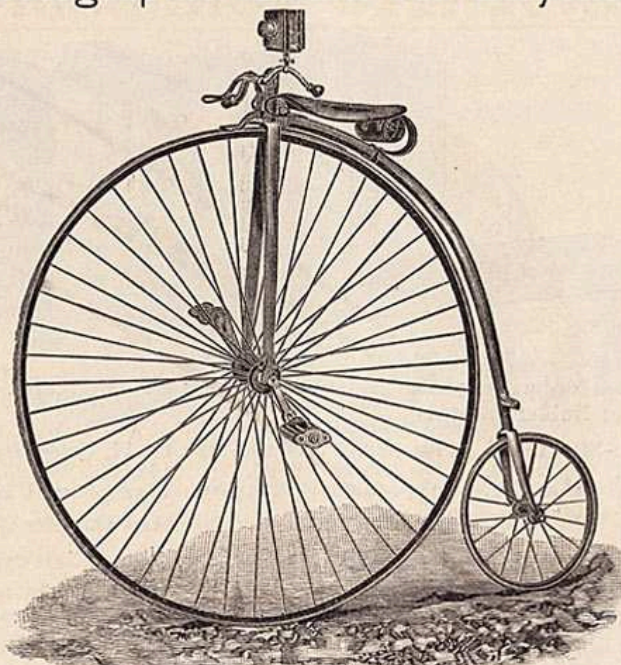

WITH WHICH TO SECURE MEMENTOES OF PLEASANT EXCURSIONS.

So popular has amateur photography become among wheelmen, that the two amusements are now often combined. The Camera allows unbounded opportunities to the amateur bicyclist to gather choice landscape views.

BICYCLISTS' "POCKET" PHOTO-OUTFIT,

Consisting of a 3½x4½ "Pocket" Camera, with Double Dry Plate Holder, with *patent Registering Slides* and Hinged Ground Glass. This Camera weighs only 12 ounces.

A UNIVERSAL JOINT BICYCLE ATTACHMENT.

A. S. M. C. INSTANTANEOUS LENS, with Stops.

The "Pocket" Bicycle Camera weighs only 12 ounces.

PRICE, - - - \$12.00.

NICKEL-PLATED BICYCLE ADJUSTABLE SUPPORT.....\$1.50
This has no loose pieces, and is so accurately made as to have no side play.

THE "MIGNON" BICYCLISTS' PHOTO-OUTFIT,

(COMPLETE).

Consisting of a 3½x4½ Finely Polished Mahogany Camera, with Swing Back, Vertical Shifting Front, Hinged Ground Glass, Folding Bed, with *Patent Latch*, Rack and Pinion Movement (Front Focus).

A *Universal Joint Bicycle Attachment*.

A *Morrison Bicycle Lens*, pronounced by authorities on optics to be without a peer.

A *Canvas Saddle Bag* lined with flannel, to prevent marring of the fine finish of the camera.

Price of "Mignon" Bicyclists' Photo-Outfit Complete, \$50.00.
Without Lens \$25.00.

With the lenses just described, clear, sharp pictures can be obtained which will make fine transparencies and lantern slides, or they can be enlarged up to 8x10 size.

The Scovill Enlarging, Reducing and Copying Cameras.

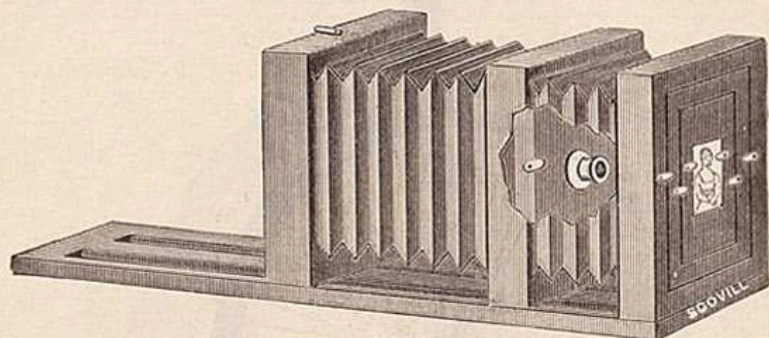

When ordering, please specify number and sizes of kits, also style of Holder wanted.

No. 61.—Size, 6½x8½, Price, \$30.00	No. 64.—Size, 11x14, Price, \$60.00
“ 62. “ 8x10, “ 35.00	“ 65. “ 14x17, “ 72.00
“ 63. “ 10x12, “ 48.00	“ 66. “ 17x20, “ 90.00
No. 67.—Size, 20 x 24, . . . \$110.00.	

Special sizes and styles made to order.

The form of construction of this new Camera is made apparent by the illustration here shown. The experienced copyist will not need any such simple directions for use as we append.

DIRECTIONS FOR USE.

To copy a negative in the natural size, place it in the kit on the front of Camera and button it in. Attached to the center frame of the Camera is a division upon which, on the side toward the Camera front, a Lens is mounted. Suppose this to be a quarter-plate Portrait Lens, the focal length of which we will suppose to be 4 inches—draw back the center frame and the Lens twice the focal length of the Lens (8 inches); slide the back frame with ground glass the same distance from the center frame. To enlarge with the same Lens to eight times the size of the original, the center of the Lens must be 4½ inches from the negative, and the ground glass be 36 inches from the center of the Lens. To reduce in the same proportion, reverse and have 36 inches from the center of the Lens to the negative, and from the center of Lens to ground glass 4½ inches.

WALMSLEY'S PHOTO-MICROGRAPHIC CAMERA.

Manufactured by the **American Optical Co.** Now in use by many Colleges and leading Microscopists throughout the country, and is an efficient, practical and cheap instrument for the purpose.

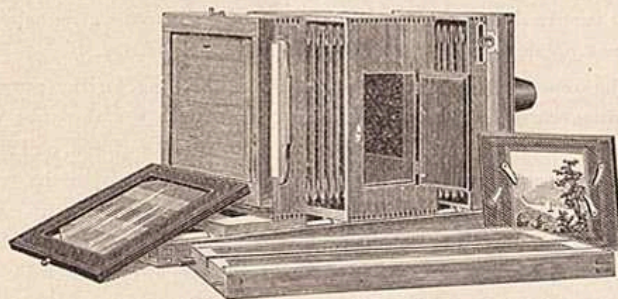

It is made in two forms: the cheaper (selling for \$18.00) is adapted only to the making of negatives on plates 3¼x4¼, or 4¼x5½, as may be necessary. The complete form (costing \$30) is also a miniature enlarging, reducing, and copying camera, admirably adapted to the production of lantern transparencies from any size negative up to 4¼x5½.

The camera (of mahogany) is square, carrying a Flammang single plate holder for 4¼x5½ plates; usable vertically or horizontally, and with kits for 3¼x4¼ plates. The bellows are in two sections, with a central division of mahogany, which carries a removable partition, to which a suitable rectilinear photographic lens can be attached, for enlarging, reducing, or copying. A light-tight door on one side of this wooden section gives ready access to the lens for inserting or removing diaphragms, or other necessary manipulations, whilst a milled head, accessible from the same opening, clamps the lens-bearing section firmly to the bed of the camera a any desired point.

The bellows have an extension of two feet in addition to the length of the box, sliding very smoothly upon V-shaped ways, which for greater convenience are made in two sections, firmly attached to each other by wooden dowels, and a solid brass screw, worked by a milled head.

The bellows are firmly held at any desired point of extension by a cam, operated by a lever conveniently placed at the rear of the focusing screen which latter is hinged at the bottom, and when not in use, lies out of the

way upon the extension bed. The screen itself is of the very finest ground glass, but is used only for arranging the portion of the object to be photographed properly in the center of the plate, as no surface can be ground finely enough to permit the sharp focusing of any delicately-lined object. For this purpose, a circle or disc of thin microscopic covering glass is attached with balsam to the center of the ground glass screen, which clears away all the inequalities of the latter, and leaves an exquisitely fine surface to receive the image, which by using an ordinary focusing glass may be as sharply defined as in the eye-piece of the microscope.

The front of the camera (which is double-shifting, for the purpose of centering), carries a cone-shaped tube, which receives the tube of the microscope when the latter is inclined to a horizontal position, and conveys the image-bearing rays of light therefrom into the body of the camera. This cone is removable, and in its place may be inserted kits, carrying negatives from quarter to half size, for enlargement or reduction to lantern slides as may be desired. Or a front board, bearing a lens, may be inserted in its place, converting the camera into a copying one. Indeed, a more complete instrument for all the purposes for which it was devised could scarcely be conceived or desired.

In use, the camera is attached to a solid platform (which also carries the microscope and lamp) by a screw such as is used with an ordinary tripod. By this means any jar or tremor produced by a passing vehicle or other means, is communicated to microscope and camera alike, preventing any diminution of sharpness in the negative. By this arrangement also, the whole apparatus is so compact that, with the bellows closed, the operator can easily see the image upon the ground glass, and at the same time reach the milled heads upon the microscope controlling the stage and focusing movements, permitting the arrangement of the subject with the greatest nicety. But when the bellows extended to their full length, some appliance becomes necessary to operate the fine adjustment of focus, whilst the eye can discern the changes upon the screen. This is most simply effected in the employment of a fine cord passing in a groove around the periphery of the milled head of the fine adjustment screw, and thence through a series of hook eyes to the rear of the camera bed, where it is held taut by a couple of leaden weights. The slightest pull upon either cord moves the fine adjustment screw with the utmost nicety.

PRICE.

Walmsley Micro-Camera.....	\$18 00
" " enlarging, reducing, and copying pattern ..	30 00

SCOVILL'S OUTFIT

For PHOTOGRAPHING with the MICROSCOPE.

Photographing with the microscope has hitherto been accomplished by the aid of elaborate and costly apparatus, and been applied chiefly to making illustrations for scientific magazines. The process used, that of wet collodion in connection with sunlight, involved the procurement of an expensive heliostat to produce a steady illumination, for with any less powerful light the exposure would necessarily be so prolonged that the coating of the plate would dry and become useless. Now all this is changed, for with the modern improvements in photography which are the result of the introduction of gelatine dry plates, the photographing of microscopic objects becomes as easy of accomplishment as the photographing of the beautiful and visible in nature is with the popular amateur outfits.

The scientist and microscopist, instead of spending hours in making imperfect drawings, aided by the camera lucida, may in a few minutes, with the assistance of photography, produce a more perfect representation of a minute object than it is possible for the hand of man to do, working conjointly with the eye. Not only can an enlarged image of a microscopic object be formed for illustration, but professors in colleges will find it a ready means to produce negatives of a suitable size from which may be made transparencies or magic lantern slides for exhibition to classes or the public.

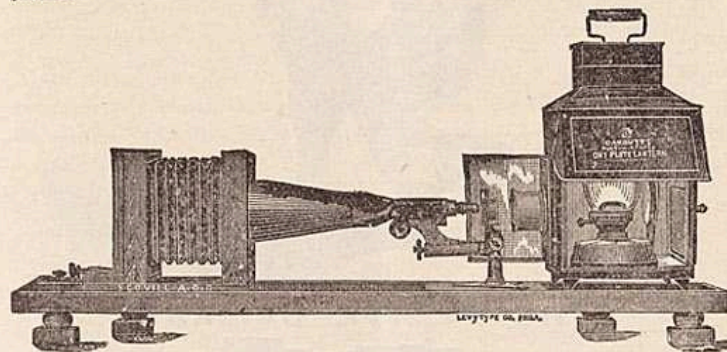

If this is done in the daytime, a room from which all white light is excluded should be selected; but if used at night, as in most cases it would be, the operations may all be performed in the midst of a family group for their interest and amusement, and to impart to them knowledge of the minute life or organisms of the world which the microscope alone can reveal.

Scovill's Photomicroscopic Equipment,

— CONSISTING OF —

- 1 Scovill Special Half Plate Camera.
- 1 Multum in Parvo Lantern, with Double Condenser.
- 1 dozen $4\frac{1}{2} \times 5\frac{1}{2}$ size B Keystone Plates to make Negatives; also
- 1 dozen $3\frac{1}{2} \times 4\frac{1}{4}$ size A Plates for Transparencies.

Price, Complete, \$18.00.

The presumption is that you are provided with a microscope. If not, we recommend the purchase of one from a regular dealer in microscopical goods.

Circular containing directions for use sent with each outfit.

MERCER Photo-Micrographic CAMERA.

Size, $2\frac{3}{4} \times 3\frac{1}{4}$.

Price, \$7.50.

This Camera is provided with a Brass Cone and Plate Holder with Ground Glass attached, to slide back and forth in the carriage, as desired.

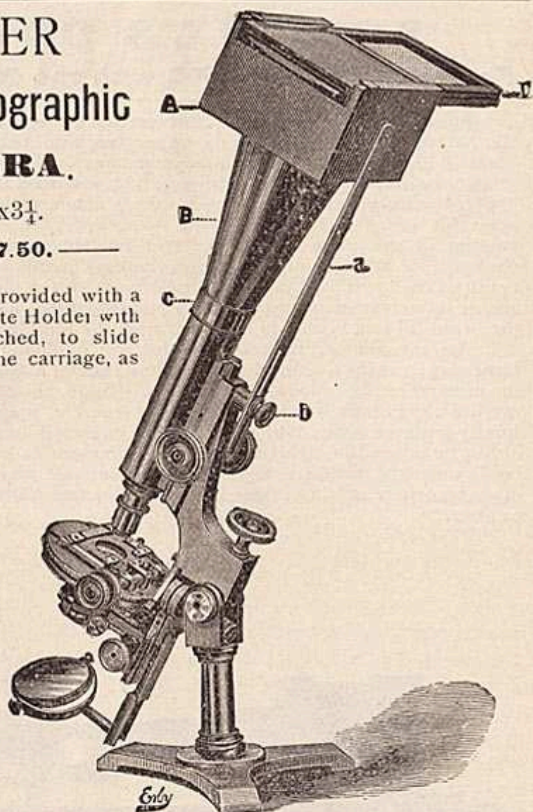

THE PETITE CAMERA.

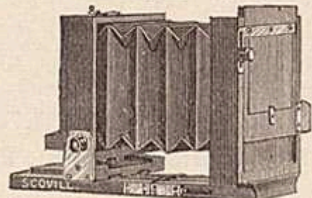

This camera was made to suit the refined taste of one of Vassar's fair students. The design on the part of the manufacturers was to reduce the impedimenta for an outing to the minimum, providing a $3\frac{1}{2} \times 4\frac{1}{2}$ camera (to make negatives of suitable size for lantern slides), with single swing, folding bed with patent latch, vertical shifting front, and other desirable improvements. So well has the design been carried out that many ladies will follow the example of Vassar's pupils, and learn the fascination of picture-taking with one of these finely-polished mahogany cameras. Gentlemen in search of a pocket camera need not seek further. The Petite Camera and an enlarging camera will by many be considered a satisfactory and complete equipment for such photographing as they desire to do.

PRICE.

Petite Camera with one double Dry-Plate Holder, and patent Registering Slides... \$12 00
Same Camera with canvas bag, with shoulder strap and Scovill's Adjustable
(feather weight) Tripod..... 17 00

WATERBURY LENSES.

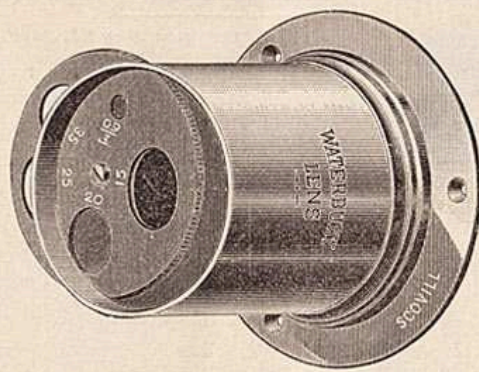

The unprecedented success which has everywhere resulted from the employment of the Waterbury Lenses, for 4×5 and 5×8 plates respectively, induced the Scovill Mfg. Co. to extend the series of this favorite objective. The popular C Waterbury Lens gave opportunity for producing 8×10 and even 10×12 photographs with the sharpness, detail and brilliancy of the smaller sizes, but after its advent there was still a gap between the 5×8 and 8×10 sizes. The desire to see the Waterbury series complete has led to the production of the B B Waterbury Lens, which covers $6\frac{1}{2} \times 8\frac{1}{2}$ (the ever-popular 4—4 size) to the extreme edges. In future, revolving diaphragms will be supplied with all of the Waterbury Lenses. In them, are cut (with mathematical accuracy) openings in value $F/15$ $F/20$ $F/25$ $F/35$ $F/60$ respectively.

The Waterbury Lenses are composed of a bi-convex crown glass lens cemented to another lens of the plano-convex form, made of the best selected flint glass.

Owing to the great advances in the sensitiveness of emulsion plates, the Waterbury Lenses are now commonly used for groups and for instantaneous views, with the Scovill Safety Shutters, described on another page. No better testimony can be given to the excellence and reliability of these objectives, and the mathematical accuracy with which they are made, than that deduced from the recent test made of 392 lenses of the C series, in which large number only two lenses differed at all in focal length or luminous power from the others.

A, Single, for 4×5 plate.....	\$3 50
A, Matched pair, stereoscopic.....	7 00
B, Single, for 5×8 plate.....	4 50
BB, Single, for $6\frac{1}{2} \times 8\frac{1}{2}$ plate.....	6 00
C, Single, for 8×10 plate.....	8 00

The Wale Universal Lenses.

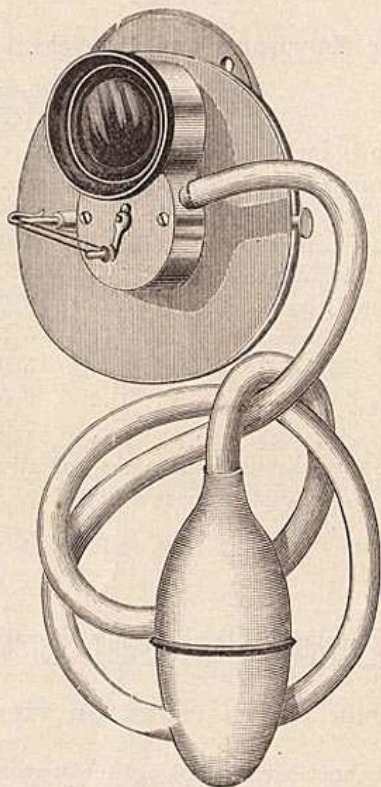

For Landscapes, Groups, Portraits, and Instantaneous Views.

6 in.	back focus, for	5	x	8	Plates and under	(without Shutter)	..	\$25 00
6	"	"	"	5	x	8	"	"
							{ (with Instantaneous and Time Shutter)	35 00
8	"	"	"	6½	x	8½	"	"
							(without Shutter)	33 00
8	"	"	"	6½	x	8½	"	"
							{ (with Instantaneous and Time Shutter)	43 00
10	"	"	"	8	x	10	"	"
							(without Shutter)	40 00
10	"	"	"	8	x	10	"	"
							{ (with Instantaneous and Time Shutter)	50 00

GUNDLACH

Rapid Rectigraphic Lenses.

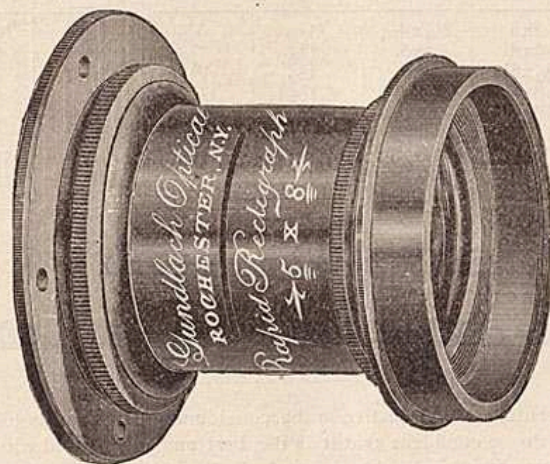

The splendid qualities of the **Rectigraphic** (it being constructed on a principle superior to that employed in the construction of any other photographic lens in the market), have won for it, in the short time it has been before the photographic public, a well recognized place in the front rank of photographic objectives.

It possesses all the qualities required to make it equally valuable for either Landscape or Portrait Work. For the latter purpose we recommend especially the larger sizes, from No. 4 up. When used with the Modern Dry Plate they will equal the best Portrait Lenses in rapidity, while, with their full opening, they have wonderful depth and microscopic sharpness.

The RECTIGRAPHIC is superior to any lens in the market in flatness of field, and is the only one that can be focused sharp at the extreme edge of the field, being free from astigmatism.

Each lens is supplied with a set of Diaphragms in a morocco case.

GUNDLACH

Rapid Rectigraphic Lenses.

DESCRIPTION AND PRICE.

No.	Size of Plate.	Size of Portrait.	Diam. of Lenses.	Back Focus.	Equivalent Focus.	Price.
1	4x5	3¼x4¼	1	5⅞	6¼	\$20.00
2	5x8	4x6	1¼	7½	8	30.00
3	6½x8½	5x8	1½	9¼	10	38.00
4	8x10	6½x8½	1¾	11	12	50.00
5	10x12	8x10	2	13½	14¼	64.00
6	11x14	10x12	2¼	15¼	16½	76.00
7	14x17	12x15	2⅝	17½	19	125.00
8	17x20	16x18	3	20	22	150.00

GUNDLACH

Wide-Angle Rectigraphic Lenses.

In presenting this Objective to the consideration of the photographic public, we do so confident that it is the best and most rapid wide-angle Photographic objective in the market. It is absolutely rectilinear, and possesses, in so far as any wide-angle lens can, the qualities that have won so much favor for the RAPID RECTIGRAPHIC.

No.	Size of Plate.	Diameter of Lenses.	Back Focus.	Equivalent Focus.	Price.
1	5x7	⅞ in.	4⅞ in.	4½ in.	\$24.00
2	6½x8½	1⅞ "	5½ "	6 "	30.00
3	10x12	1½ "	7⅞ "	8 "	40.00
4	14x17	2 "	9¾ "	10½ "	55.00
5	17x20	2⅝ "	13⅞ "	14 "	80.00

List of Caps, Diaphragms, Etc., for the Rapid Rectigraphic Lens.

	1	2	3	4	5	6	7	8
Flange.....	\$0.45	\$0.65	\$0.75	\$1.00	\$1.30	\$1.60	\$2.50	\$3.00
Diaphragms.....	.80	1.20	1.75	2.25	2.75	3.40	5.75	6.75
Case.....	.35	.40	.45	.50	.65	.75	1.25	1.50
Caps.....	.35	.40	.45	.50	.65	.75	1.25	1.50

IMPORTED LENSES.

Ross Rapid Symmetrical Lenses,

FITTED WITH WATERHOUSE DIAPHRAGMS.

Size of View.	Size of Group.	Diameter.	Equiv. Focus.	Price.
4 x 5	3¼x 4¼	1 inch.	6 inch.	\$34 00
5 x 6	4 x 5	1¼ "	7½ "	42 00
5 x 8	4½x 7½	1⅝ "	8½ "	46 00
6½x 8½	5 x 8	1⅞ "	11 "	52 00
8 x 10	6½x 8½	2 "	13 "	68 00
10 x 12	8 x 10	2¼ "	16 "	84 00
11 x 13	9 x 11	2½ "	18 "	92 00
12 x 15	11 x 14	2¾ "	20 "	116 00
16 x 18	12 x 15	3 "	24 "	148 00
18 x 22	16 x 18	3½ "	30 "	200 00
22 x 25	18 x 22	4 "	34 "	240 00

These lenses are free from "flare" and distortion, and give absolutely straight marginal lines, rendering them invaluable for all kinds of architectural subjects, dimly-lighted interiors, copying, and instantaneous work.

Ross Portable Symmetrical Lenses.

For landscapes, architecture or copying; giving wide or ordinary angles, according to the stop used. A great favorite with English amateurs. Unequaled for photographic work.

No.	Large Stop.	Med. Stop.	Small Stop.	Equiv. Focus.	Price.
a 3	4 x 5	4½x 7½	5 x 8	5 inch.	\$28 00
a 4	4½x 7½	5 x 8	6½x 8½	6 "	32 00
5	5 x 8	6½x 8½	7 x 9	7 "	40 00
6	6½x 8½	7 x 9	8 x 10	8 "	48 00
7	7 x 9	8 x 10	10 x 12	9 "	56 00
8	8 x 10	10 x 12	11 x 14	10 "	64 00
9	10 x 12	11 x 14	12 x 15	12 "	72 00
10	11 x 14	12 x 15	16 x 18	15 "	80 00
11	12 x 15	16 x 18	18 x 22	18 "	96 00
12	16 x 18	20 x 22	21 x 25	21 "	120 00

STEINHEIL LENSES.

QUALITY, not quantity, governs in determining the price of lenses. By an examination of the following price list, which supercedes all previous ones, it will be seen that Steinheil lenses are sold lower than any first-class lenses with which alone they may be compared. The introduction of Steinheil lenses marked an important advance in photographic optics.

HOW TO SELECT A STEINHEIL LENS.

In order to meet the various requirements, and to insure in each special case as perfect work as possible, we make lenses of different constructions.

Our lenses are divided into six *series*, presented in the order of their respective rapidities. Each series begins with No. 1 for the smallest size, and continues upwards. To avoid errors, it is therefore necessary in ordering to quote both the number of the series and the number of the lens in the present catalogue.

All our lenses are rectilinear and are strictly corrected for spherical errors and chemical focus.

They are free from disturbing reflections, and strongly illuminated objects can be taken with them without producing flare or light spots. They are, moreover, constructed so as to give the greatest possible equality of definition over the whole picture.

In focusing with these lenses, it is advisable to use the largest stop, even when it is intended to work with the smallest.

The scientific basis of our establishment and the precise methods employed both in the manufacture of our astronomical and photographic apparatus, enable us to produce lenses of such uniform accuracy, that the means of most vigorous testing at our command fail to reveal any differences in the instruments we send out.

We make it a special point never to supply a lens which is capable of improvement at our hands.

According to the principle involved in their construction, our lenses consist chiefly of two classes, viz.: *Antiplanatic* and *Aplanatic*.

Antiplanatic Lenses.

(U. S. Patent Nos. 241,437-'8.)

Briefly stated, these lenses which are the result of a series of calculations extending through several years, are composed of two non-symmetrical combinations each of as great but opposite faults as possible, which correct each other. One combination has a shorter focus than the objective as a whole, and the other has a negative focus. The combinations are placed very closely together.

By the peculiar construction, as described above, differing widely from the usual forms, it has been possible to correct to a considerable extent the hitherto greatest defect in photographic objectives, viz., "Astigmatism," and the consequent rapid decrease of definition from the center to the margin of the picture.

The result is greater sharpness and depth distributed more equally over a larger and strictly even picture, before any decrease in definition is perceptible.

Illumination, too, is more evenly distributed in consequence of lenses being proportionately nearer together.

These properties allow the lenses to be worked with full aperture or large stops, and gives them great rapidity of action.

The perfectly correct delineation produced by the antiplanets render them particularly suitable for enlargements as well as for dissolving view apparatus.

If small and sharp originals are taken, and subsequently enlarged, depths are obtained which would be unattainable in larger pictures taken *direct* with same amount of light. For this purpose, which will probably play an important part in photography, the antiplanets are specially suitable.

In making enlargements the front lens of the antiplanets should always be turned towards the enlarged picture, and the back lens towards the object to be enlarged.

This construction is designed for strictly even and correctly delineated pictures, and all tilting of the camera should be decidedly avoided and a movable lens board used instead.

The antiplanets are made in two series: The portrait antiplanets (Series I.) and the group antiplanets (Series II.), the latter being, however, also excellent dry plate portrait lenses.

Aplanatic Lenses.

These lenses consist of the original and now well-known symmetrical and rectilinear combinations. They are made in four series, each of which is especially designed for a certain class of work. Their capabilities and object are fully explained below.

The lenses of Series V., also Series III., No. 1; Series IV., Nos. 1 and 2 have rotary diaphragms.

All the other lenses are furnished with Waterhouse diaphragms in morocco case.

STEINHEIL LENSES.

Series I.—Portrait Antiplanatics.

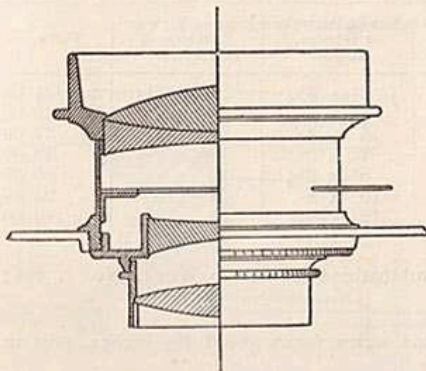

The rapidity is the same as in the usual Portrait Objectives, but there is more equality in the distribution of sharpness and illumination over the picture and greater depth. Contrary to the ordinary Portrait Objectives they produce perfectly correct delineation. Designed for *Portraits, Enlargements, and Dissolving View Apparatus.*

Series I.—Portrait Antiplanatics.

No.	Aperture, Inches.	Focal Length, Inches.	Plate, Inches.	Price.
1.....	$\frac{5}{8}$	2	Locket-Size.	\$25 00
1a.....	$1\frac{1}{8}$	$4\frac{1}{4}$	1-9 plate.	50 00
1b.....	$2\frac{5}{8}$	$7\frac{1}{8}$	1-6 plate.	75 00
2.....	3	$9\frac{1}{2}$	1-4 plate.	100 00
3.....	$3\frac{5}{8}$	$12\frac{5}{8}$	1-2 plate.	165 00
4.....	$5\frac{1}{4}$	$23\frac{5}{8}$	4-4 plate.	330 00

Special quotations for larger sizes.

Series II.—Patent Antiplanatic Group Lens.

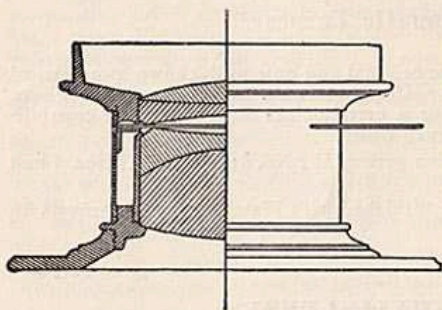

New in principle and construction, consisting of two non-symmetrical cemented pairs, placed so closely together, that there is only just room for the diaphragm. It is rectilinear, and is remarkable for its powerful and even illumination and depth of focus. In rapidity, it is only excelled by the regular and expensive portrait combinations.

Designed for *Portraits, Groups, Architecture, Landscape, Instantaneous Work and Enlargements.*

No.	Aperture, Inches.	Focal Length, Inches.	Size of Portraits or Groups, Inches.	Size of View or Landscape, Inches.	Price.
1.....	11-16	$3\frac{3}{4}$	$3\frac{1}{4} \times 3\frac{1}{4}$	$4\frac{1}{4} \times 3\frac{1}{4}$	\$21 00
2.....	1	$5\frac{5}{8}$	$4\frac{1}{4} \times 3\frac{1}{4}$	5 x 4	28 00
3.....	1 5-16	$7\frac{1}{4}$	5 x 4	7 x 5	37 00
4.....	1 11-16	$9\frac{1}{2}$	7 x 5	$8\frac{1}{2} \times 6\frac{1}{2}$	48 00
5.....	$1\frac{7}{8}$	$10\frac{7}{8}$	$8\frac{1}{2} \times 6\frac{1}{2}$	10 x 8	60 00
6.....	$2\frac{1}{2}$	$14\frac{1}{8}$	10 x 8	12 x 10	95 00
7.....	3 1-16	$17\frac{3}{4}$	12 x 10	15 x 12	140 00

Price for two identical combinations for Stereo Work, No. 1, \$44; No. 2, \$60; No. 3, \$77.

Detective camera lens of this series, focus about $4\frac{3}{4}$ inches, now in preparation.

Series III.—Aplanatic Lens.

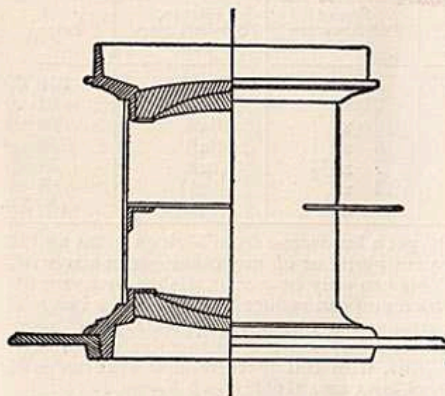

The prototype of all rapid symmetrical and rectilinear lenses. Is now made with increased illumination and rapidity. Next to the Antiplanatic Group Lens, Series II., it is the best lens for general work. Designed for *Portraits, Groups, Architecture, Landscape and Instantaneous Work.*

No.	Aperture, Inches.	Focal Length, Inches.	Size of Portraits or Groups, Inches.	Size of View or Landscape, Inches.	Price.
1.....	$\frac{1}{4}$	$1\frac{5}{8}$	For enlarging,		\$ 18 00
2.....	$\frac{5}{8}$	$3\frac{3}{4}$	$3\frac{1}{4} \times 3\frac{1}{4}$	$4\frac{1}{4} \times 3\frac{1}{4}$	18 00
3.....	1	$5\frac{5}{8}$	$4\frac{1}{4} \times 3\frac{1}{4}$	$5\frac{1}{2} \times 4\frac{1}{4}$	25 00
4.....	$1\frac{1}{4}$	$7\frac{1}{2}$	$5\frac{1}{2} \times 4\frac{1}{4}$	7 x 5	32 00
5.....	1 11-16	11	$8\frac{1}{2} \times 6\frac{1}{2}$	10 x 8	44 00
6.....	2 1-16	$14\frac{1}{8}$	10 x 8	12 x 10	57 00
7.....	$2\frac{3}{8}$	$17\frac{3}{8}$	12 x 10	14 x 11	86 00
8.....	2 15-16	21 3-16	17 x 14	20 x 17	125 00
9.....	3 7-16	25	20 x 17	22 x 18	166 00
10.....	4 9-16	33	22 x 18	24 x 20	245 00

Price for two identical combinations for Stereo Work, No. 2, \$38; No. 3, \$52; No. 4, \$67.

Series IV.—Landscape Aplanats.

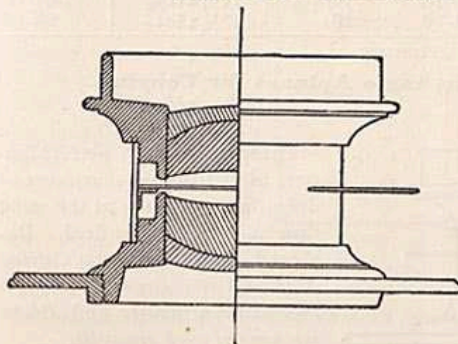

Angle about 75 deg., and covering a larger field than the lenses of Series III. Specially designed for *Landscape Work and Architecture*, but can also be advantageously used for *Copying*.

Series IV.—Landscape Aplanats.

No.	Aperture. Inches.	Focal Length. Inches.	Size of Full Aperture. Inches.	Picture, Smallest Stop. Inches.	Price.
1.....	3-16	2 $\frac{3}{8}$	2 x 1 $\frac{1}{2}$	3x2 $\frac{1}{2}$	\$18 00
2.....	3-8	3	2 $\frac{1}{2}$ x2	4x3	21 00
3.....	1 $\frac{1}{2}$	4 $\frac{3}{4}$	3 $\frac{3}{4}$ x3	6x5	26 00
4.....	3/4	6 $\frac{3}{8}$	5 x4	8x6	32 00
5.....	1	9 $\frac{1}{2}$	7 x5 $\frac{1}{2}$	11x8	44 00
6.....	1 $\frac{1}{2}$	15 $\frac{3}{8}$	10 x8	14x11	86 00
7.....	2 $\frac{1}{8}$	23 $\frac{3}{8}$	14 x11	20x16	160 00

It is frequently desirable to get a landscape from a given point and to get it just of the size to cover your plate, or of any other given size without changing your position. This can only be accomplished by using objectives of different foci, by which you can reduce or enlarge the image at will. For this work we have arranged a *Set of Four Landscape Aplanats*, fitting in the same flange, aperture 1 in., and foci respectively 9 $\frac{1}{2}$, 12 $\frac{5}{8}$, 15 $\frac{3}{4}$ and 19 ins., covering 7x5 $\frac{1}{2}$ ins. with full aperture, and 11x8 ins. with smallest stop. Price, in neat lock-up case, \$168.

Sets of any number and class of aplanats made to order at proportionate prices.

Series V.—Wide-Angle Aplanat.

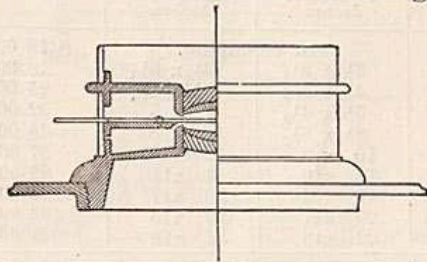

The proportionately short focus and large angle (about 100 deg.) of these lenses make them particularly adapted for *Interiors, Architecture*, and for very high, broad objects taken from short distances.

No.	Aperture. Inches.	Focal Length. Inches.	Size of Sharp Pictures. Inches.	Price.
1.....	3-16	3 $\frac{3}{4}$	5 x5	\$26 00
2.....	5-16	4 $\frac{3}{4}$	7 x7	30 00
3.....	7-16	7 $\frac{1}{4}$	10 $\frac{1}{4}$ x10 $\frac{1}{4}$	42 00
4.....	9-16	10 $\frac{3}{8}$	12 $\frac{1}{4}$ x12 $\frac{1}{4}$	61 00
5.....	14-16	16	18 $\frac{1}{2}$ x18 $\frac{1}{2}$	93 00

Special quotations for larger sizes.

Series VI.—Wide-Angle Aplanat for Copying.

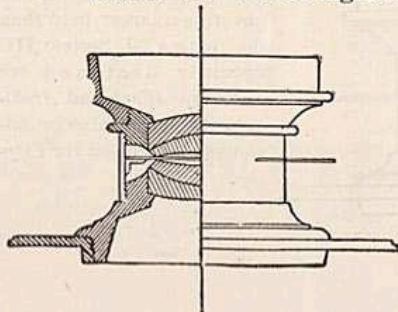

These lenses give perfect flatness of picture and sharpness of definition, and have at the same time a considerable field. Designed specially for *Copying Maps, Charts, Drawings, Paintings and Engravings* and *Photo mechanical work generally*.

Series VI.—Wide-Angle Aplanat for Copying.

No.	Aperture. Inches.	Focal Length. Inches.	Size of Sharp Picture. Inches.	Price.
1.....	1	14 $\frac{3}{8}$	10 x 10	\$75 00
2.....	1 $\frac{1}{4}$	18	13 x 13	105 00
3.....	1 $\frac{3}{4}$	23 $\frac{5}{8}$	17 x 17	145 00
3b.....	2	30 $\frac{3}{4}$	20 x 20	210 00
4.....	2 $\frac{1}{2}$	38 $\frac{3}{8}$	24 x 24	320 00
5.....	3	48 $\frac{1}{4}$	28 x 28	540 00
6.....	3 $\frac{1}{2}$	56	34 x 34	760 00

Special quotations for larger sizes.

These lenses are rapidly gaining favor in the photo-mechanical establishments throughout the United States, whose operators pronounce them superior to all others for the special work for which they have been constructed.

As a result of our experience we beg to point out particularly the necessity of avoiding the slightest vibration during exposure, when it is desired to obtain the extremest sharpness of picture which these lenses are capable of producing. It is also advisable not to use too small a diaphragm as the diffraction caused thereby veils the picture.

For obtaining inverted negatives, without stripping the film, we have designed the Prisms of Series VII, which can be fitted to the above or any other lenses.

Series VII.—Prisms.

These prisms are made of one solid homogenous mass of glass, with silvered hypotenuse.

They are centered in their mountings and adjustable to our lenses simply by unscrewing the hood of the lens and screwing the prism in its place.

With every prism is furnished a rotary flange with set screw, allowing the prism to be turned and fixed at any angle to the horizon. Designed for making *Inverted Negatives without stripping the film*.

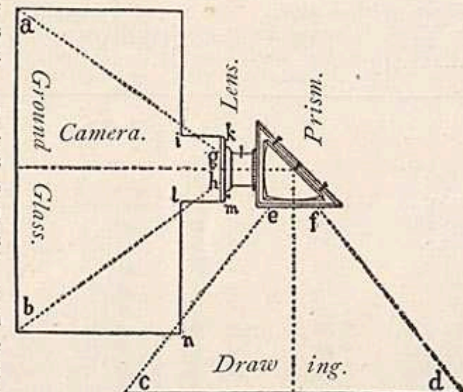

Series VII.—Prisms.

No.	To work with Lenses as follows:	Price.
1	Ser. III. No. 2, Ser. IV. No. 3, Ser. IV. No. 4.....	\$37 00
	Ser. V. No. 1, Ser. V. No. 2.....	
2	Ser. IV. No. 5, Ser. V. No. 3, Ser. VI. No. 1.....	41 00
3	Ser. III. No. 3, Ser. VI. No. 2.....	45 00
4	Ser. II. No. 2, Ser. III. No. 4, Ser. V. No. 4.....	57 00
5	Ser. IV. No. 6, Ser. V. No. 5.....	68 00
6	Ser. II. No. 3, Ser. VI. No. 3.....	80 00
7	Ser. III. No. 5, Ser. VI. No. 3 $\frac{1}{2}$, Ser. VI. No. 4.....	110 00
8	Ser. IV. No. 7.....	125 00
9	Ser. II. No. 4, Ser. III. No. 6, Ser. VI. No. 5.....	155 00
10	Ser. VI. No. 6.....	185 00
11	Ser. III. No. 7.....	287 00
12	Ser. III. No. 8.....	493 00

No charge made for fitting the above Prisms to Steinheil Lenses. For fitting to other makes of lenses the labor will be charged for at cost.

Series VIII.—Aplanatic Focusing Lenses.

These are a combination of three lenses, so constructed that, at a considerable focal distance and large field, they produce an even, undistorted picture, achromatic both inside and outside of the axis.

No.	Focal Length.	Linear Magnifying Power.	Price.
1.....	2 $\frac{3}{8}$ in. about 3 $\frac{1}{2}$ times.....	\$12 00
2.....	1 $\frac{5}{8}$ " " 5 ".....	10 00
3.....	1 " " 8 ".....	8 00

Beck Autograph Rectilinear Lenses.

None genuine without this engraved on the tube.

R. J. Beck.

These Lenses possess qualities entirely their own.

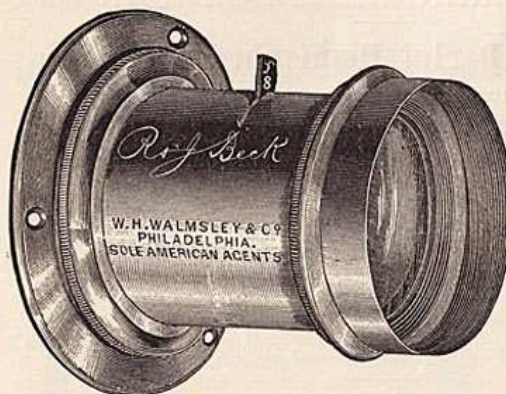

5 x 4. ACTUAL SIZE.

These Lenses are perfectly Aplanatic, covering with full aperture to the extreme corners the size plate for which they are designated in the list, and much larger sizes when moderately stopped down. They are very rapid in action rendering them particularly valuable for instantaneous and short-time exposures; are rigidly rectilinear and symmetrical; possess wonderful penetration and definition, and are the lightest

and most compact of any lenses in the market—a matter of no small moment to the landscape photographer. The No. 5 Lens will make life-size heads, sharp and free from distortion. They are in use in many of the leading galleries of the country.

No.	Size of Plate.	Diameter of Lenses.	Back Focus.	Equiv'lent Focus.	Angle.	Price.
1	3 $\frac{1}{4}$ x 4 $\frac{1}{4}$	$\frac{7}{8}$ in.	4 $\frac{1}{2}$ in.	5 in.	75°	\$25 00
2	4 $\frac{1}{4}$ x 5 $\frac{1}{2}$	1 in.	6 in.	6 $\frac{3}{4}$ in.	70°	30 00
3	5 x 8	1 $\frac{1}{4}$ in.	8 in.	8 $\frac{3}{4}$ in.	64°	35 00
4	6 $\frac{1}{2}$ x 8 $\frac{1}{2}$	1 $\frac{1}{2}$ in.	10 $\frac{1}{4}$ in.	11 in.	67°	50 00
5	8 x 10	1 $\frac{3}{4}$ in.	12 $\frac{1}{4}$ in.	13 in.	66°	60 00
6	10 x 12	2 in.	14 $\frac{1}{2}$ in.	16 in.	66°	75 00
7	11 x 14	2 $\frac{1}{4}$ in.	16 $\frac{3}{4}$ in.	18 in.	66°	100 00
8	14 x 17	3 in.	22 in.	24 in.	66°	160 00
9	20 x 22	3 $\frac{3}{4}$ in.	27 $\frac{1}{2}$ in.	30 in.	66°	200 00

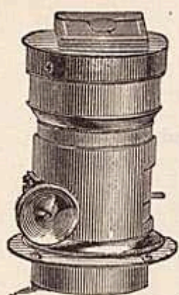

Darlot Portrait Lenses.

RACK AND PINION, WITH CENTRAL STOPS.

1-4 size, 4½ inch focus.....	\$8 75
1-2 " 7 "	17 50
4-4 " for 8-10 plates, 10½ inch focus...	35 50

The ½ size we can furnish in matched pairs.

Darlot Quick Working Portrait Lenses.

RACK AND PINION, WITH CENTRAL STOPS.

1-2 size, 5½ inch focus.....	\$22 00
4-4 " 8½ "	43 00



Darlot Hemispherical.

WIDE-ANGLE RECTILINEAR VIEW LENSES.

These Lenses embrace an angle of 90 degrees, and are valuable for taking views of buildings, interiors, etc., in confined situations, where those of longer focus cannot be used.

No.	Back Focus.	Size View.	Price.
No. 1,	2½ inches.....	For Stereoscopic Work, each.....	\$12 50
" 2,	3 "	" "	15 00
" 3,	5 "	8 x 10.....	20 00
" 4,	8 "	10 x 12.....	25 00
" 5,	12 "	14 x 17.....	35 00

Darlot Rapid Hemispherical View Lenses.

These Lenses embrace an angle of from 60 to 75 degrees; are quick-acting, perfectly rectilinear, and provided with central stops. Will be found very fine lenses for landscapes and outdoor groups; also for copying engravings, maps, architectural subjects, etc.

No.	Back Focus.	Size View.	Price.
No. 1,	5½ inches.....	5 x 6.....	\$15 00
" 2,	9 "	5 x 8.....	25 00
" 3,	10½ "	8 x 10.....	35 00
" 4,	14 "	10 x 14.....	50 00

No. 1 can be had in matched pairs for Stereoscopic work.

Darlot Gem Lenses.

PLAIN.

1-9 size, each.....	\$2 50
1-4 " "	3 75

Scovill Time and Instantaneous Shutter.

That the substitution of a pneumatic release for the ordinary trigger on a wood drop-shutter greatly enhances its value. "goes without saying."

The Scovill Time and Instantaneous Shutter

Is Fitted with Pneumatic Attachment.

which may be worked at a considerable distance from the Camera, thus enabling the operator to form part of a group or to be included in a view he is photographing. This Shutter may be used for either timed or instantaneous exposures; the change is made by simply moving a switch.

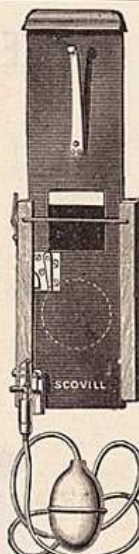

Scovill Safety Shutter, with Time and Instantaneous Attachment.

SCOVILL UNIVERSAL SAFETY SHUTTERS.

This Shutter is styled Universal, not only because more of the Scovill Safety Shutters are in use than of any other pattern, but because it can be arranged with a variety of openings, from ¼ to 2 inches at the center, as shown by the dotted lines of the accompanying illustration. Uniform distribution of light over the plate is insured by the form of opening.

The brakes on all of these Shutters make them safe to use, by preventing a recoil with the resulting double exposure, and the jarring common to many Shutters, which in time breaks apart the glasses of a Lens where cemented together—hence the designation "Safety Shutters."

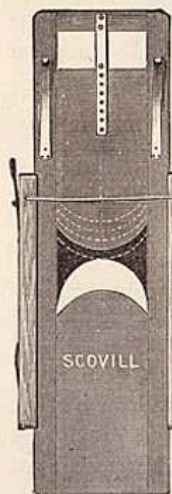

Scovill Universal Shutter.

PRICE LIST.

No.	Width of Opening in Slide.	Scovill Universal Shutters.	Universal Shutters, with Pneumatic Release.	Scovill Safety Shutters.	Safety Shutters, with Pneumatic Release.	Universal Time and Instantaneous Shutter, with Pneumatic Release.
1	1¼ ins.	\$2.70	\$4.20	\$1.20	\$2.70	\$4.70
2	1½ "	2.80	4.30	1.30	2.80	4.80
3	1¾ "	2.90	4.40	1.40	2.90	4.90
4	2 "	3.00	4.50	1.50	3.00	5.00
5	2½ "	3.10	4.60	1.60	3.10	5.10
6	3 "	3.25	4.75	1.75	3.25	5.25

When ordering these Shutters, exact diameter of hood of Lens should be given, so that the proper circular opening may be cut out to exactly fit hood of Lens. If not stated, the Shutters will be sent without the round opening being cut.

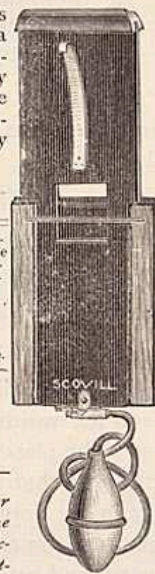

Scovill Safety Shutter.

THE KELLOGG INSTANTANEOUS SHUTTER.

Price, \$5.00.

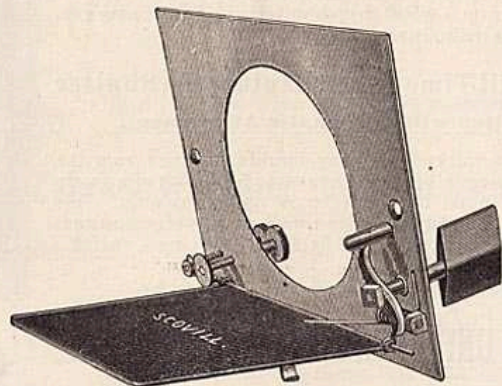

DESIGNED ESPECIALLY FOR INSTANTANEOUS WORK
UPON BOTH LAND AND WATER.

Is always in position ready for a "shot." Cannot receive any accidental injury, as it is situated inside the Camera and worked from the outside.

The effect of hinging the door at its lower side is to have the ground receive a longer exposure than the sky, which is a great advantage.

With the thumb-screw which controls the tension of the closing mechanism, the time of exposure can be varied at will.

To focus, push in button under adjusting screw, which opens the shutter and holds it open.

To adjust the shutter it is simply necessary to remove the nuts from the inside ends of the spindles; remove the spindles and fasten the plate to the inside of the camera front by two small screws, so that the circular hole in the plate coincides with the hole in the front board for the lens; three holes having previously been made in the front board so that the three spindles can be replaced, and can turn easily in their bearings.

"DUPLEX"

Photographic Shutter.

For Timed or Instantaneous Work.

PERFECT IN BOTH.

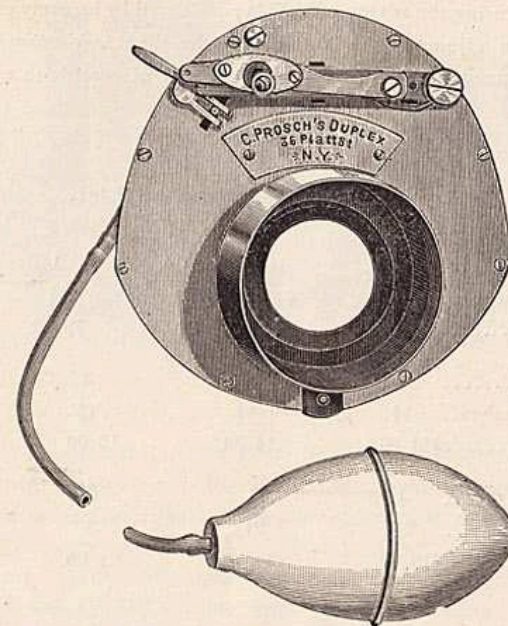

SPECIAL ATTENTION is directed to the "**PROSCH RAPID**" Shutter. With this new Shutter the limit of attainable rapid work (even when the quickest plates are used), depends on the ability of the operator to develop the exceedingly rapid exposures it will make, attaining as it does a rapidity close to the $\frac{1}{1000}$ part of a second. Like the Duplex, this Shutter is placed between the lenses, but its construction and operation in nowise resembles it. Made in two sizes, with diaphragm openings of one inch, price, \$18.00; and $1\frac{1}{2}$ inch, price, \$22.00.

The Duplex Stethoscopic Shutter supplies perfectly a well recognized want. It is arranged for the two lenses at $3\frac{1}{4}$ inches from centres, and has diaphragm openings of $\frac{3}{4}$ inch. It is substantially two No. 00 Duplex Shutters operated in unison by one lever bar. The price is \$18.00. Rotary Stops, \$2.00. Silent (*self-setting*) time and *slow* instantaneous attachment, \$1.50 extra.

The Duplex Detective Shutter supplies the long-felt want for a reliable, compact, and efficient shutter for detective cameras, which can be used for both *time* and *instantaneous* work. Price, including rotary stops and fitting to detective box, \$15.00. Send box and lens with order.

The very popular "**DUPLEX**" Shutter (triple improved) still retains its place head and shoulders above its competitors. The rotary stop introduced during the season of 1887 is considered by an army of users an indispensable adjunct to the shutter; and the silent (*self-setting*) time and *slow* instantaneous attachments, devised at end of season, is equally appreciated.

Duplex Enlarged Revised List.

Numbers.....	00	0	0A	1	1A
Openings, inches..	$\frac{5}{8}$	$\frac{7}{8}$	1	$1\frac{1}{8}$	$1\frac{3}{8}$
Prices.....	\$11 50	12 00	12 50	13 00	13 50
Numbers	2	2A	3	3A	
Openings, inches..	$1\frac{1}{8}$	$1\frac{3}{8}$	$1\frac{5}{8}$	2	
Prices.....	\$14 00	14 50	16 00	17 00	
Numbers.....	4	5	6	7	
Openings, inches..	$2\frac{1}{4}$	$2\frac{3}{4}$	3	$3\frac{1}{4}$	
Prices.....	\$18 00	20 00	22 00	25 00	

Rotary Stops up to No. 1, \$1.50; above that, \$2.00 extra.

Silent time attachment, same price as rotary stops.

When flange collars are required, as on Ross and lenses similarly mounted, 50 cents extra. As a rule, Shutters are furnished with stop opening about size of next to largest stop.

Shutters can be furnished for most standard lenses fitted ready for use; but it is to customer's interest to forward his lens tube with order, otherwise perfect fit is not guaranteed

SCOVILL MAGIC FINDERS.

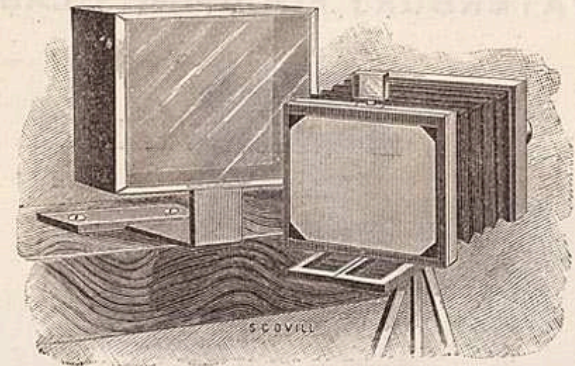

THE Scovill' Magic Finders will at once be preferred to any and all others. One sees through them a marvelously clear *non-reversed* image the *exact proportion* of the reversed one on the ground-glass. The Magic Finders are light, ornamental, easily adjusted and detached, and will certainly be pronounced a great convenience by all view takers.

PRICE LIST.

No. 1, for 4 x 5 Camera,	- - -	\$1.50
" 2, " 5 x 8 "	- - -	1.75
" 3, " $6\frac{1}{2} \times 8\frac{1}{2}$ "	- - -	2.25
" 4, " 8 x 10 "	- - -	2.75

Examine a sample, and be convinced of their superiority.

C. C. H. FOCUSING GLASS.

This is a desirable little instrument for aiding the operator in getting a sharp focus.

C. C. H. FOCUSING GLASS.....\$4 00
 Darlot Focusing Glass..... 2 50
 Scovill's 3-legged Focusing Glass, each..... 75



Save your eyes by using one of these instruments.

WATERBURY FOCUSING GLASS.

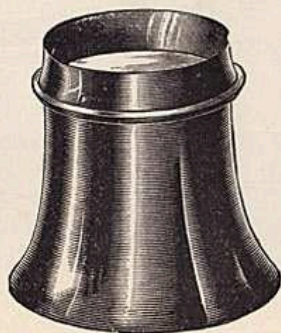

Waterbury Focusing Glass, Rubber.....each, \$0 40

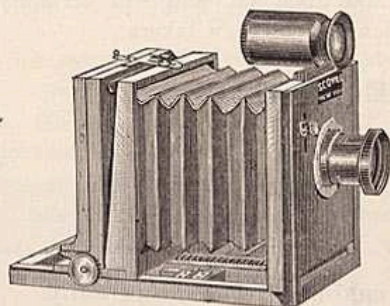

THE
 "WATERBURY FINDER,"
 Each \$3.00.
 To Attach to Camera
 FOR
 Instantaneous Work.

PEERLESS FINDER,
 Each, \$1.50.

Eastman-Walker Roll Holders.

Model of 1887.

3¼ x 4¼.....\$ 9 00	5 x 7\$12 50	11 x 14.....\$30 00
4 x 5 10 00	5 x 8 12 50	14 x 17..... 40 00
4¼ x 5½..... 10 00	6½ x 8½..... 16 00	17 x 20..... 50 00
4¼ x 6½..... 10 00	8 x 10 20 00	18 x 22..... 60 00
4¾ x 6½..... 12 50	10 x 12 24 00	20 x 24..... 75 00

FRENCH AND GERMAN SIZES.

9 x 12 cm.....\$ 9 00	18 x 24 cm.....\$16 00
13 x 18 " 12 50	21 x 27 " 20 00

In ordering, be sure and specify Model of 1887.

All fitted with new the single revolution audible indicator.

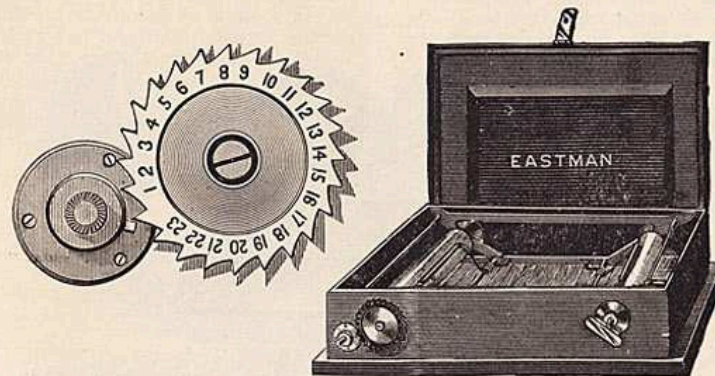

Patented May 5, 1885. Label Registered, 1885.

No Roll Holder is complete without this tally to record the number of exposures made.

Price of Automatic Tally, \$5.00 extra.

All sizes of Roll Holders up to and including 11 x 14 carried in stock. Larger sizes to order.

Roll holders on Scovill Detective Cameras have the American Optical Co. Automatic Tally fitted to them.

Roll Holders.—EXTRA PARTS.

All parts of Roll Holders are made interchangeable, and any part can be furnished on application.

Extra Keys, old model... 25 cts. each.

EXTRA REELS.

3 1/4 inches.....	50 cts.	11 inches.....	\$1 00
4 "	50 "	14 "	1 00
4 1/2 "	50 "	16 "	1 25
4 3/4 "	50 "	17 "	1 25
5 "	50 "	18 "	1 25
6 1/2 "	75 "	20 "	1 50
8 "	75 "	25 "	2 00
10 "	75 "		

Extra Reels enable the operator to remove the exposed paper from the roll holder without separating the exposures or rewinding the paper film, an operation that should always be avoided. Enough extra reels should be provided to carry all exposures that are intended to be made before developing. For instance, if 100 exposures are to be made on a trip, 3 extra reels are required. Each reel, as soon as full, is removed from the holder and replaced by another to take the paper from a fresh spool. The boxes in which the spools are sold serve to store the reels of exposed paper. Empty spools are thrown away.

Film Carriers.

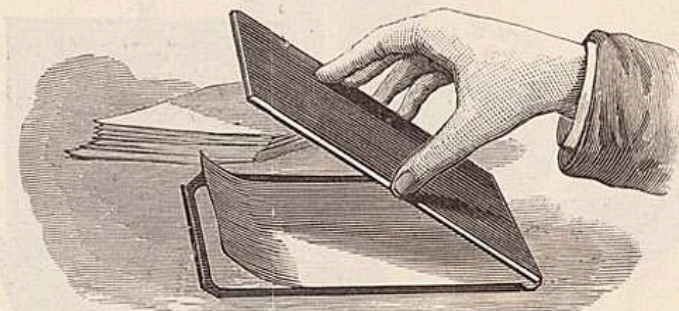

Patented May 5, 1885.

3 1/4 in. thick.	4 in. thick.	4 1/2 in. thick.	5 in. thick.	5 1/2 in. thick.	6 in. thick.	6 1/2 in. thick.	7 in. thick.
3 1/4 x 4 1/4 ..	\$0 25	—	8 x 10 ..	\$0 50	\$0 50	\$0 50	—
4 x 5 ..	30	—	10 x 12 ..	—	—	60	—
4 3/4 x 6 1/2 ..	30	—	11 x 14 ..	—	—	75	—
5 x 7 ..	35	—	14 x 17 ..	—	—	1 00	—
5 x 7 1/2 ..	35	—	16 x 20 ..	—	—	—	\$1 25
5 x 8 ..	35	35	18 x 22 ..	—	—	—	1 50
6 1/2 x 8 1/2 ..	40	40	20 x 24 ..	—	—	—	1 75

Sizes not mentioned are not made and cannot be furnished. In ordering carriers specify which thickness is wanted. The thicker the carrier the more rigid.

Double Holders that have the plate slide in from the end require the thinnest carrier, (3/8).

The Daisy Holder will take the 1/8 inch carriers when the septum is removed. As the carriers are opaque, the septum is not required.

Wet Plate Holders require the 3/8 carriers.

Magnesium Flash-light Photographs.

Since the introduction of the Scovill Magnesium Cartridges, photographs are made instantaneously which could not otherwise be secured without great expense, trouble, and danger, in caves, tunnels, mines, and other places where daylight does not penetrate, and what is

Equally important and of more general interest, Instantaneous Photographs of Family Groups in the house; Merry Guests at the festive board; Theatre, Fancy Dress, and Card Parties, Etc.,

are now made in the evening, with the valued surroundings, under the happiest auspices which but a short time ago the most skilled photographer would not have thought possible to secure.

It seems almost incredible that any one should continue to use compounds which are known to be of an explosive nature. The various substances used to make actinic Magnesium light are no secrets; some are easily explosive, some are dangerously poisonous, and yet, for some fancied advantages which they offer in a compound, manufacturers are willing to put them upon a confiding public, and photographers seem ready to risk their lives, or at least the danger of severely injuring themselves by using them. Even when great caution is used, an explosive compound is always dangerous, and had better be left untouched. If there were no good compounds which were free from dangerous properties, there might be some excuse for adhering to the use of those which are known to be explosive and poisonous, but such is not the case.

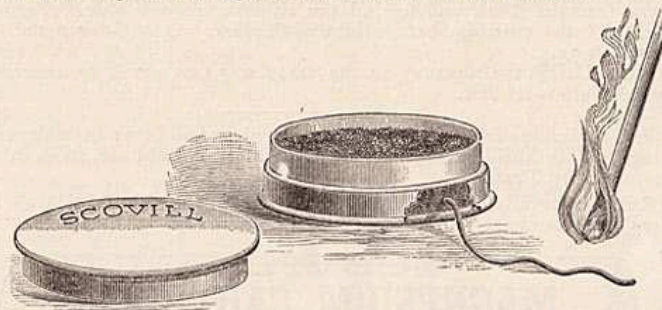

A Magnesium Compound, prepared in form of a cartridge, is now on the market, which unites the every excellent quality of extremely actinic light, with convenience of ignition and perfect safety as to its non-explosive nature, and absence of poisonous or other objectionable elements. It is prepared in different quantities and put up in boxes, so that the light may always be at hand in convenient shape for using. The cap, too, which fits neatly over the cartridge, protects it from dampness, so that the light may be employed out-of-doors on a damp day, or even during a gentle rain. A fuse is inserted at the bottom of the cartridge, so that there is no danger of a premature explosion with a consequent burning of the hand, as is often done when a charge of the powder is ignited by a match or short taper. The combustion is instantaneous, with no detonation, and there follows no poisonous or otherwise obnoxious gases or vapors from the burning. Out-of-doors with the cap on, the combustion is quite as instantaneous, and the light nearly equal in its intensity.

Scovill Albums FOR Photographs.

(NEW STYLE.)

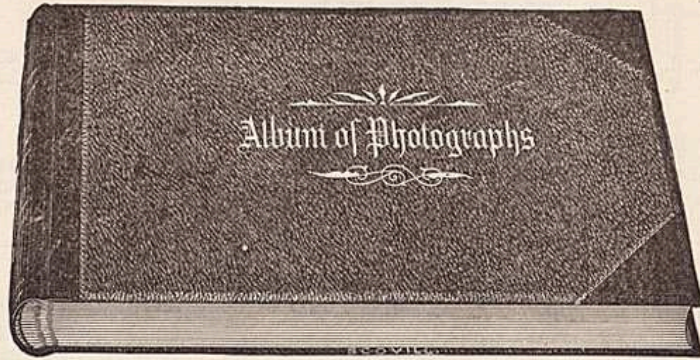

How often the Amateur Photographer is heard to remark, that as fast as he makes prints from a negative his friends get away with them, and none are left to be treasured up as evidences of his advancement in the art. In order to keep at least one picture from each negative, and to arrange the collection in the best manner for display and preservation, tasteful albums have been introduced by the Scovill Manufacturing Co.

Each Album has 48 pages, 24 leaves. In them the finest card-board only is used, chemically free from anything that could injure a print.

PRICES:

Size of Card	6x7	7x10	10x12	11x14	14x17
For Photo. (size)	4x5	5x8	6½x8½	8x10	11x14
Plain	\$1.25	1.50	2.25	2.50	5.00
With Prepared Surface	1.50	1.80	3.00	3.50	6.50
With Gilt Lines	1.75	2.00	2.75	3.00	

The Scovill Porte-Feuille

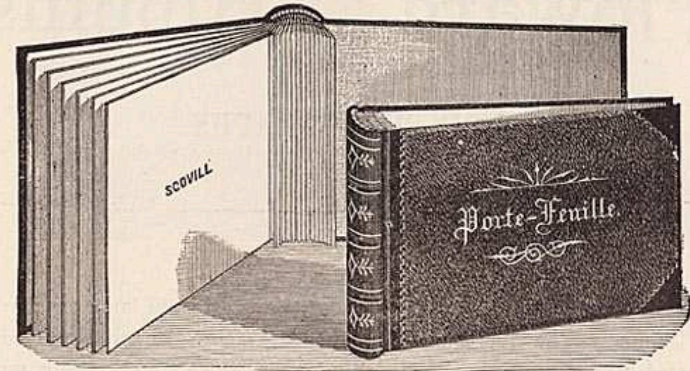

Is a device for the preservation, in convenient form, of cards upon which photographic prints have been mounted.

A series of muslin holders, bound between covers with patent flexible backs, constitute a book having great strength of binding combined with a flexibility that allows the book to be opened flat without strain. Prints can thus be put into book form, readily and securely, after they have been mounted and also (when desired) burnished. The insertion of the cards is very simple, as will be seen by the directions which follow: To the inner faces of one of the holders apply enough paste to attach the card securely; not so much as will smear the exposed face of the card; then insert the card and rub down on both sides; allow the paste to dry before putting in another card.

Do not put the Paste on the Card.

PRICE LIST OF PORTE-FEUILLE,

Including Twenty-five Sheets of Collins' Best Quality White Cards.

No. 1.	Outside dimensions, 7 x 10 for 5 x 8 Photographs.	\$1 50
" 2.	" " " 10 x 12 for 6½ x 8½	2 10
" 3.	" " " 11 x 14 for 8 x 10	2 50

Price List of Porte-Feuille, including 25 Sheets of Collins' White Muslin-Back Cards.

No. 4.	Outside dimensions, 7 x 10 for 5 x 8 Photographs.	\$1 35
" 5.	" " " 10 x 12 for 6½ x 8½	2 00
" 6.	" " " 11 x 14 for 8 x 10	2 40

Price List of Cards per package of 25, not including Porte-Feuille.

COLLINS' BEST WHITE CARDS.

7 x 10	\$0 50		10 x 12	\$0 75
11 x 14					\$1 00.

COLLINS' WHITE MUSLIN-BACK CARDS.

7 x 10	\$0 35		10 x 12	\$0 65
11 x 14					\$0 90.

Collins' White Muslin-Back Cards, in Rolls, 22 inches wide, 14 cts. per yard.

Howard :: Albums

FOR PHOTOGRAPHS.



THE Howard Album, with interchangeable cards, is the latest novelty in the way of an album for mounting photographs. In handsomely embossed covers, are bound 25 of Collins' cards, which are chemically pure from all matter that would injure the photographs. In the mode of binding, and their interchangeable feature, lies the difference between this and other albums.

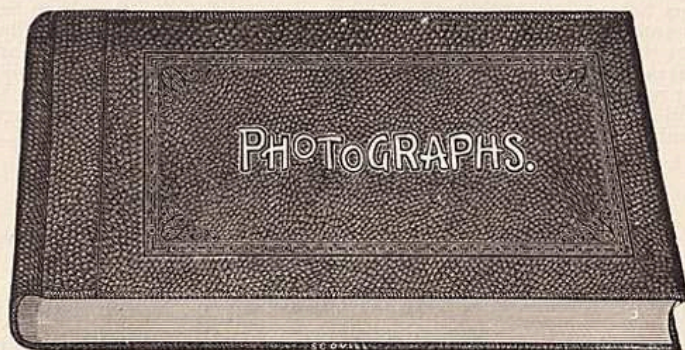

To each card are attached two small metallic binding loops, so fastened that they act like hinges; through the projection of these loops a binding cord passes, which fastens at the back with a tie; thus each card is bound in the cover independently, and may be taken out and returned or replaced with ease. This method of making an album affords the amateur the best means of preserving the results of his labor, because each picture may be finished before putting the card in the album. The arrangement of the pictures may also be altered at will—if a single card is spoiled, the whole album is not ruined. If a picture is taken out, it can be quickly and readily done without injury to the volume.



HOWARD ALBUMS.

Full Cloth, Embossed, Gold Label, with A. M. Collins Mfg. Co.'s No. 1 Cards.

	With 25 Collins Cards.
No. 1. — 6x 7 Cards, for 4 x 5 Photographs,	\$1 25
“ 2. — 7x10 “ “ 5 x 8 “	1 50
No. 2½.— 8x10 “ “ 6½x 8½ “	2 00
“ 3. —10x12 “ “ 6½x 8½ “	2 25
“ 4. —11x14 “ “ 8 x10 “	2 50

HOWARD ALBUMS.

Morocco, Half Leather, Extra Gold Finish, with A. M. Collins Mfg. Co.'s Cards, Boxed.

	With 25 Collins Cards.	With 50 Collins Cards.
No. 5.— 7x10 Cards, for 5 x8Photographs	\$2 25	No. 11.—\$3 50
“ 6.— 8x10 “ “ 6½x8½ “	2 75	“ 12.— 4 00
“ 7.—10x12 “ “ 6½x8½ “	3 50	“ 13.— 4 75
“ 8.—11x14 “ “ 8x10 “	4 00	“ 14.— 5 50
“ 9.—14x17 “ “ 10x12 or 11x14	5 50	“ 15.— 9 00
“ 10.—16x20 “ “ 11x14 “ 14x17	7 75	“ 16.—11 00

Extra Cards Collins' Best for Howard Albums, Mounted with Loops, Ready for Use.

6x 7, Package of one dozen.....	\$0 38
7x10, “ “ “	50
8x10, “ “ “	60
10x12, “ “ “	62
11x14, “ “ “	88
14x17, “ “ “	1 25
16x20, “ “ “	1 55

HOWARD FOTO-FOLIOS.

THESE Foto-Folios are different from the ordinary Port-Folios made for holding etchings, photographs, etc., in having flat Cords, which are used to draw and bind the covers firmly together. On the sides and end of the Folio are jointed flaps, which prevent damage by dust or rubbing of the edges. The Cords are so arranged that the Photographs, etc., are kept perfectly flat, whether there be one or a number in the Folio.

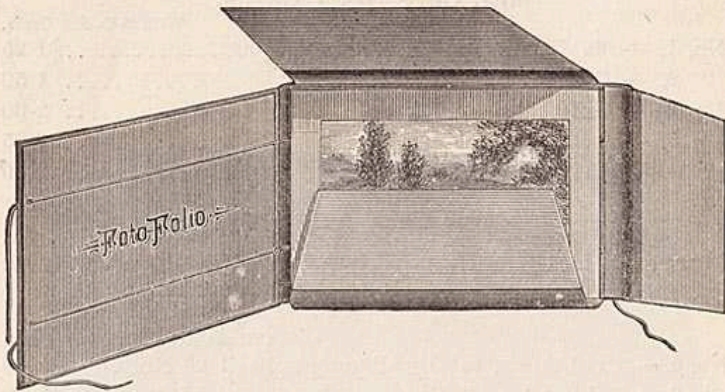

Two Styles, Full Cloth, and Half Leather Embossed, Gilt Lines.

	For Cards.	Size Folio.	Thickness when filled.	Price cloth, ea.	Half Leather.	Full leather Special.
No. 17,	4½ x 6½	4½ x 6¾	1¼	\$ 65		\$1 10
" 18,	5 x 8	5¼ x 8½	1½	80	\$1 25	
" 19,	6½ x 8½	7¼ x 9¼	1½	1 10	1 75	
" 19a	7 x 9	7¼ x 9¼	1½	1 10	1 75	
" 20,	8 x 10	8½ x 10½	1¾	1 35	2 00	
" 21,	10 x 12	11¼ x 14½	2	1 60	2 50	
" 21a	11 x 14	11¼ x 14½	2	1 60	2 50	
" 22,	14 x 17	14½ x 17½	2¼	2 00	3 00	
" 23,	16 x 20	16½ x 20½	2½	2 50	3 50	

Special Styles and Sizes to order. Prices furnished on application.

THE HOWARD ALBUM COVERS FOR PHOTOGRAPHS.

SELF-BINDING. INTERCHANGEABLE.

COLLECTIONS of photographs of authors, statesmen, composers and other celebrities, may be made, and the binding into these Albums done at home. Landscapes, seascapes, and special studies may be arranged in these covers for use in the school, library and counting room.

Old and valued accumulations of photographs may be arranged for reference, and preserved by use of these covers.

For family groups these self-binding covers are unequalled, as they make a complete album, whose contents may be re-classified, and present a finished appearance, whether as few as two photographs, or any number up to the limit, twenty-five are bound in.

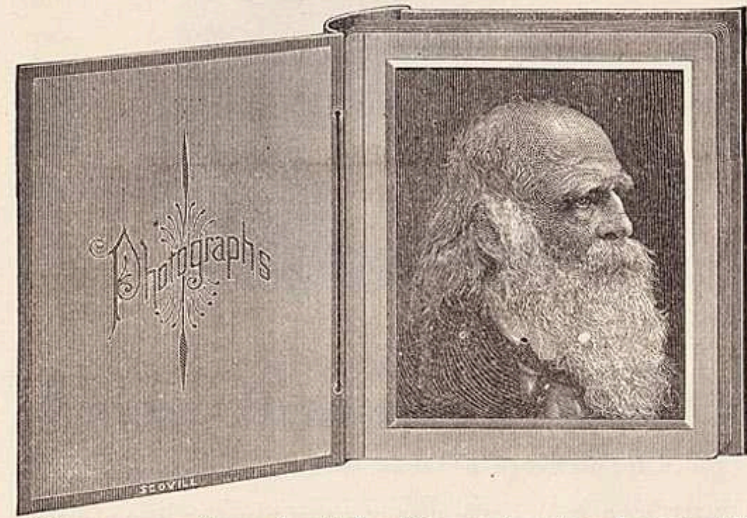

These covers have beveled edges and extra heavy sides, tastefully embossed and finished with gilt side title. In each a beveled card is bound in, as a frontispiece, to illustrate the method of use of the interchangeable binding fasteners.

Twenty-five Fasteners, with adhesive edges, accompany each cover, and to these the photographs are easily and securely attached. When the fasteners with photographs attached are bound into the covers, the result is a photographic album more desirable than any hitherto seen, because the photographs may be rearranged as often as desired, without injury to them or to the Album.

THE HOWARD PHOTOGRAPH COVERS.

SELF-BINDING. INTERCHANGEABLE.

Order Nos.	Size of Cards.	Price.	Price.	Price.
		FULL CLOTH.	HALF LEATHER.	SPECIAL, FULL LEATHER.
No. 24.....	4¼ x 6½	\$0 65		\$1 10
" 25.....	5 x 8	80		
" 26.....	6½ x 8½	1 00	\$1 50	
" 27.....	7 x 9	1 10	1 75	
" 28.....	8 x 10	1 25	2 00	
" 29.....	10 x 12	1 50	2 25	

These prices include 25 patent interchangeable Fasteners.

W. & C.

PERFECT PRESERVING TUBES

FOR SENSITIZED PHOTOGRAPHIC PAPERS.

(PATENT APPLIED FOR.)

COMPACT, RELIABLE, AIR-TIGHT.

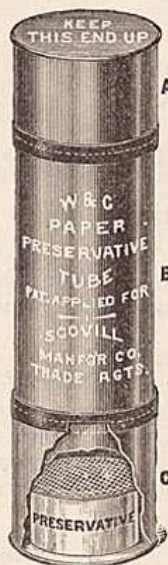

No. 1. Holds 4 x 5 to 4 1/4 x 6 1/2 (Preservative extra)	\$0 90
" 2. " 5 x 7 to 5 x 8	" " 1 10
" 3. " 6 1/2 x 8 1/2 to 8 x 10	" " 1 50
" 4. " 18 x 22	" " 2 00
" 5. " 18 x 22 Gallery use	" " 3 00

THE

W. & C. Perfect Paper Preservative

Will keep Sensitized Paper FRESH and BRILLIANT FOR MONTHS.

✓ EIGHT YEARS in constant use in Europe.

Paper can be silvered on dull, cloudy days, and used whenever needed. Proof Paper always fresh and ready for use.

PRICE OF PERFECT PRESERVATIVE.

Tin box, size for Nos. 1, 2, and 3 Tubes	each, \$0 25
Tin box, " " 4 and 5	" " 0 30

TRANSFEROTYPE PAPER.

Patented October 14, 1884.

CUT SHEETS.

SIZE.	PER DOZ.	SIZE.	PER DOZ.	SIZE.	PER DOZ.
3 1/4 x 4 1/4	\$0 25	6 1/2 x 8 1/2	\$1 10	17 x 20	\$ 6 40
4 x 5	40	8 x 10	1 50	18 x 22	7 50
4 1/4 x 5 1/2	50	10 x 12	2 25	20 x 24	9 00
4 1/4 x 6 1/2	55	10 x 14	2 65	22 x 27	11 25
4 3/4 x 6 1/2	60	11 x 14	3 00	24 x 30	13 50
5 x 7	65	12 x 15	3 35	25 x 30	14 00
5 x 7 1/2	70	14 x 17	4 50	24 x 36	16 00
5 x 8	75	16 x 20	6 00	30 x 40	22 50

SPECIAL SIZES FOR PLACQUES, TILES, &c.

SIZE.	PER DOZ.	SIZE.	PER DOZ.	SIZE.	PER DOZ.
4 x 4	\$0 35	6 x 6	\$0 75	10 x 10	\$2 00
5 x 5	50	8 x 8	1 30	12 x 12	3 00

Other sizes in proportion.

If ordered in packages of less than one dozen, an extra charge of 25 cents will be made for packing.

OPAL GLASS FOR TRANSFEROTYPES.

Selected and fine ground on one side.

REGULAR SIZES.

SIZE.	PER DOZ.	EACH.	SIZE.	PER DOZ.	EACH.
3 1/4 x 4 1/4	\$0 60	\$0 05	5 x 8	\$1 44	\$0 12
4 x 5	72	06	6 1/2 x 8 1/2	2 04	17
4 1/4 x 6 1/2	1 08	09	8 x 10	2 88	24
5 x 7	1 20	10	10 x 12	4 32	36

SPECIAL SIZES.

SIZE.	PER DOZ.	EACH.	SIZE.	PER DOZ.	EACH.
4 x 4	\$0 60	\$0 05	8 x 8	\$2 40	\$0 20
5 x 5	96	08	10 x 10	3 60	30
6 x 6	1 32	11	12 x 12	5 40	45

BROMIDE COPYING PAPER.

For copying drawings, plans, etc.

This paper is similar to Permanent Bromide Paper, being coated with the same sensitive compound, and requires the same treatment in exposure and development. The paper itself is not genuine photographic paper, and is not therefore suitable for portrait work.

CUT SHEETS.

SIZE.	PER DOZ.	SIZE.	PER DOZ.	SIZE.	PER DOZ.
3 1/4 x 4 1/4	\$0 13	6 1/2 x 8 1/2	\$0 55	17 x 20	\$ 3 20
4 x 5	20	8 x 10	75	18 x 22	3 75
4 1/4 x 5 1/2	25	10 x 12	1 13	20 x 24	4 50
4 1/4 x 6 1/2	28	10 x 14	1 33	22 x 27	5 63
4 3/4 x 6 1/2	30	11 x 14	1 50	24 x 30	6 75
5 x 7	33	12 x 15	1 68	25 x 30	7 00
5 x 7 1/2	35	14 x 17	2 25	24 x 36	8 00
5 x 8	38	16 x 20	3 00	30 x 40	11 25

Other sizes in proportion.

If ordered in packages of less than one dozen, an extra charge of 25 cents will be made for packing.

EASTMAN'S NEGATIVE PAPER.

This Negative Paper is adapted for landscape and interior work and for large portraits. For these purposes it is equal to glass in all respects, and has the important advantages of portability, freedom from halation, and economy. Full directions with every package.

CUT SHEETS.

3½ x 4½, two doz. in box, \$0 65	11 x 14, one doz. in box, \$3 50
4 x 5 " " 90	14 x 17 " " 5 50
4¾ x 6½ " " 1 40	16 x 20 " " 7 25
5 x 7 " " 1 55	17 x 20 " " 7 75
5 x 7½ " " 1 65	18 x 22 " " 9 00
5 x 8 " " 1 75	20 x 24 " " 12 00
6½ x 8½ " " 2 45	24 x 36 " " 20 00
8 x 10 " " 3 50	30 x 40 " " 27 50
10 x 12, one doz. in box, 2 60	

ON SPOOLS, TO FIT ROLL HOLDERS.

3½ in. for two dozen 3½ x 4½ exposures.....	\$0 75
4 in. " " 4 x 5 "	1 00
4½ in. " " 4½ x 7½ "	1 80
4¾ in. " " 4¾ x 6½ "	1 55
5 in. " " 5 x 8 "	2 00
6½ in. " " 6½ x 8½ "	2 70
8 in. " " 8 x 10 "	4 00
10 in. " " 10 x 12 "	6 00
11 in. " " 11 x 14 "	8 00
14 in. for one doz. 14 x 17 "	6 00
16 in. " " 16 x 20 "	8 00
17 in. " " 17 x 20 "	8 50
18 in. " " 18 x 22 "	10 00
20 in. " " 20 x 24 "	13 25
25 in. " " 25 x 30 "	20 00

Spools 8 inches or under wound with 3 or 4 dozen, if required.

AMERICAN FILMS.

Patented May 5, 1885.

The American Film consists of a film of *insoluble* sensitive gelatine emulsion attached to a paper support by means of a layer of *soluble* plain gelatine. The paper serves as a temporary support during the operations of exposure, developing, fixing and washing. After which the film is laid down on a prepared sheet of glass, the paper is removed by warm water which dissolves the soluble gelatine layer and leaves the film on the glass; the paper is then replaced by a varnish of thick gelatine and glycerine, dried, and the whole stripped from the glass ready for printing. Full details of the operations outlined are given in the printed directions enclosed in every package. We recommend these Films for use where a perfectly transparent negative is required, as in enlarging.

PRICES OF AMERICAN FILMS.

CUT SHEETS.		Per Package.
Size.		
3½ x 4½, two dozen in package		\$0 70
4 x 5 " "		1 00
4¾ x 6½ " "		1 50
5 x 7 " "		1 75
5 x 7½ " "		1 90
5 x 8 " "		2 00
6½ x 8½ " "		2 80
8 x 10 " "		4 00
10 x 12, one dozen "		3 00
11 x 14 " "		4 00

FILMS ON SPOOLS, TO FIT THE EASTMAN-WALKER
ROLL HOLDERS.

Size.		Price.
3½ inch, for 24 exposures 3½ x 4½		\$0 85
4 " " " 4 x 5		1 10
4½ " " " 4½ x 7½		2 00
4¾ " " " 4¾ x 6½		1 75
5 " " " 5 x 8		2 20
6½ " " " 6½ x 8½		3 00
8 " " " 8 x 10		4 50
10 " " " 10 x 12		6 75
11 " " " 11 x 14		9 00

Other sizes in proportion.

THE SCOVILL

LIGHT-WEIGHT



Patented November 15, 1887,

and January 24, 1888.

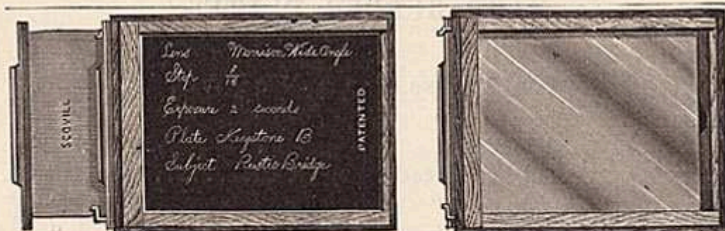
SHOWING
PATENT REGISTERING SLIDE.WITH FRONT SLIDE
TAKEN OUT

Substantial, serviceable and accurate double holders cannot be made smaller or lighter than the Scovill Light-weight Holders, and though so thin kits may be used in them. The Light-weight Holders yield a negative the full width of the plate, and, what is equally important, the plate may be placed in these holders or removed therefrom without touching the sensitive surface and without danger of breaking it. Observe the means shown in illustration for locking the slides. The Light-weight Holders are made with solid frame so that they will not come apart, leak light, or warp. Every holder has the patent Registering Slides described on the opposite page. Skilled photographers do not consider any holder complete without them. If you want to secure accurate focusing use the Light-weight, or any of the other Scovill Plate Holders.

PRICE LIGHT-WEIGHT DOUBLE HOLDER.

3 1/4 x 4 1/4, for Detective Camera.....	\$1.00	3 1/4 x 4 1/4.....	0.90	5 1/2 x 7.....	\$1.40
4 x 5, for Detective Camera.....	\$1.25	4 x 5.....	\$1.00	5 x 8.....	1.40
		4 1/4 x 5 1/2.....	1.10	6 1/2 x 8 1/2.....	1.70
		4 1/4 x 6 1/2.....	1.25	8 x 10.....	2.00
		4 3/4 x 6 1/2.....	1.30	10 x 12.....	3.50
		5 x 7.....	1.30	11 x 14.....	5.00

Light-Weight Holders can be fitted to any American Optical Co. Camera or Scovill Outfit.

REGISTERING SLIDES.

(PATENTED.)



Extract from "PHOTOGRAPHIC TIMES," March, 1884.

In the pleasure or excitement attendant upon picture-taking, holders have been so changed about that the note-book afforded no clue to their identity. All photographers, whether professional or amateur, who have in time past puzzled their brains in the endeavor to solve such vexatious questions as these—

"Have I or have I not exposed that plate?"

"If exposed, was the plate used for that prized picture?"

"Shall I incur the risk of making a double exposure?"

henceforth will have themselves only to find fault with if they do not procure and use in their dry-plate holders registering slides, or as they have been called "Record Slides." These can be written upon with slate or lead pencil *ad libitum*, and the writing erased without injury to them. Before taking a picture the mottled surface of these slides is seen; afterward they are turned, so that the blackboard surface, which was toward the sensitive plate, is out, and the data respecting the exposures are penciled thereon—a very convenient place, by the way, to consult it when developing the plates.

The material out of which these Registering Slides is made is impervious to water, and is so hard that they outlast common paper slides in the proportion of five to one. They will be supplied with new American Optical Co.'s Dry Plate Cameras and Amateur Outfits up to 10x12 size without addition to present price list. Additional Holder Slides of this kind supplied at the following prices:

PRICE REGISTERING SLIDES.

Size for	Each.	Size for	Each.
3 1/4 x 4 1/4.....	\$0 18	5 x 7.....	\$0 35
" 4 x 5.....	20	" 5 x 8.....	40
" 4 1/4 x 5 1/2.....	24	" 6 1/2 x 8 1/2.....	55
" 4 1/4 x 6 1/2.....	28	" 8 x 10.....	75

Registering Slides not made above 8x10 size.

THE SCOVILL DRY PLATE HOLDER.

(PATENTED.)

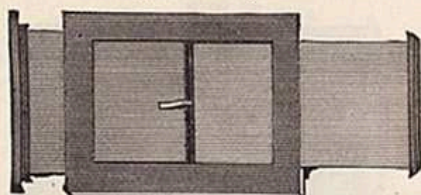

Scovill's Patent Double Dry Plate Holders are reversible, and made to receive kits.

THE DAISY DRY PLATE HOLDER.

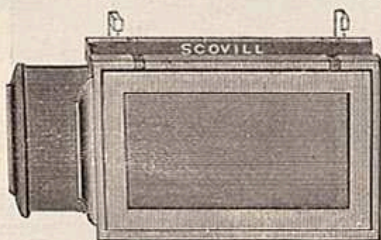

"This holder is a Daisy." The frequent repetition of this exclamation fixed the name by which our new holder is designated. It has the great merit of being lighter and of occupying less space than any other substantial holder that has ever been devised. The Daisy Holder opens like a book when the dry plates are being put into or taken out of it, and is so arranged that light cannot penetrate through from one side to the other. There are no projecting screws on this holder. What supplies their place is simple and more effective. The slides have no catches, as they are unnecessary.]

THE FLAMMANG SINGLE DRY PLATE HOLDER.

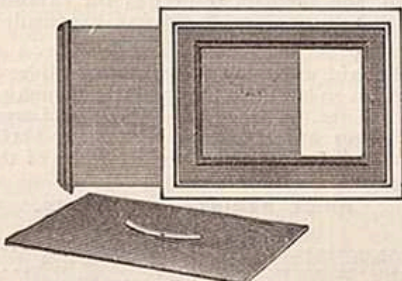

(Patented.)

ARRANGED TO TAKE KITS OF LESSER SIZE.

The Holders described on the previous page, for use in very hot or cold, or very moist climates, should be made of cherry with zinc slides. In fact, the hardwood Holders are very desirable anywhere.

Size.	Scovill's Patent Double Dry Plate Holder. Kits extra.	Daisy Double Dry Plate Holder. Kits extra.	Flammang's Single Dry Plate Holder. With Kits.
3½x4½.....	\$1 50	\$1 75	\$1 50
4x5.....	1 75	2 00	1 75
4½x5½.....	1 85	2 10	1 85
4½x6½.....	1 90	2 25	1 90
5x7.....	2 10	2 35	2 10
5x8.....	2 20	2 50	2 20
6½x8½.....	3 80	4 20	3 80
8x10.....	5 00	6 00	5 00

THE SCOVILL EXTENSION TRIPODS.

THIS Tripod possesses special advantages.

It can be set up, ready for use, quicker than any other, and with less trouble. By turning the brass buttons shown in the accompanying illustration, the legs may "in a twinkling" be extended to the desired length, and fastened. When this Tripod is placed on uneven ground, the camera it supports may be brought to the proper level by simply adjusting the length

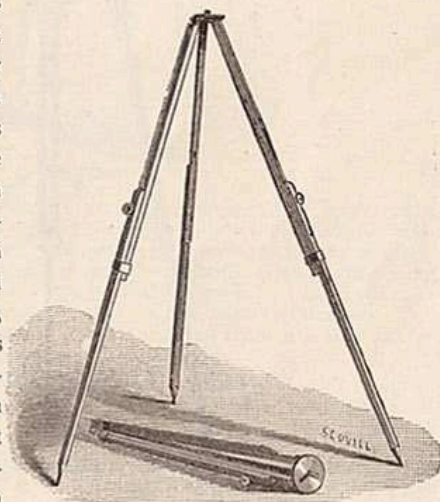

of the Tripod legs. Another commendable feature of the Scovill Extension Tripod is, that it has no detachable parts to be misplaced or lost. Combining as it does firmness, strength and lightness, this Tripod must at once find favor with the professional view taker, who very often wastes valuable time, or loses opportune moments in placing the Tripod legs and changing their position to include just what is wanted in a picture, and to level the camera. The artist for a sketching trip finds the top of this Tripod a very convenient place to fasten his Easel, as well as his camera.

No. 1, for 1-4 and 4x5 Cameras.....	each, \$3 00
" 2, " 5x8 Cameras.....	" 3 25
" 2½, " ".....	" 3 50
" 3, " 6½x8½ Cameras.....	" 5 00

THE ALBION TRIPOD.

The most elegant Tripod ever introduced is the one here illustrated. It is adapted to and is firm enough to support without vibration any View Camera from $3\frac{1}{4} \times 4\frac{1}{4}$ to 10×12 size, inclusive.

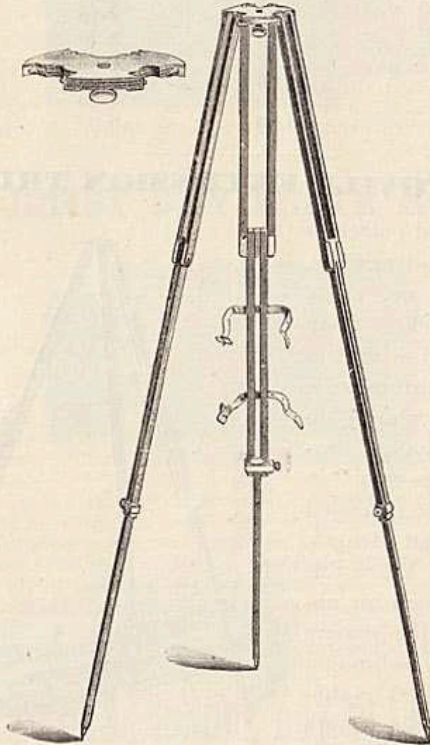

The Legs of this Tripod are adjustable as to length, and may be quickly folded. As the binding straps are attached, they are always in place when wanted.

The artistic design and faultless finish of every portion of this Tripod, which is made at the Scovill New Haven factory, cannot be realized without seeing one, and to use an ALBION TRIPOD means to be fully satisfied, and wish for none other.

PRICE, \$6.00.



The Scovill Adjustable Tripod.

(FEATHER WEIGHT.)

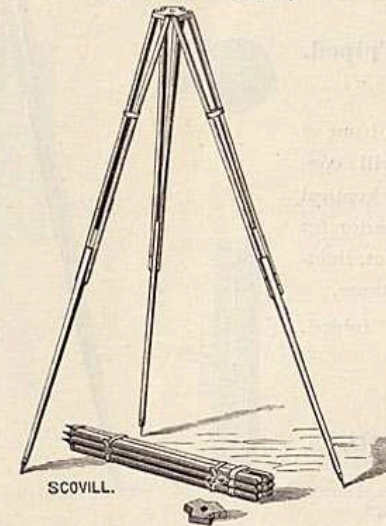

Nothing more compact, certainly nothing as graceful in appearance and light in weight as the new Tripod for out-door Photography, just produced by the American Optical Company, has yet made its appearance. Because so readily adjusted to the utmost irregularity of the earth's surface, it was decided to call it the "Adjustable Tripod." Lady amateurs prefer it to any other pattern on account of its lightness and beauty. The top is covered with billiard-cloth to prevent marring the fine polish on our cameras, and the clamping screws are not detachable.

SCOVILL ADJUSTABLE TRIPOD.

No. 1.....	Price, each, \$3.50
" 2.....	" " 5.00

Scovill Adjustable Jointed Tripod, to fold and pack in a 22-inch Valise..... \$4.00
Do. with Canvas Bag and Handle.. 4.75

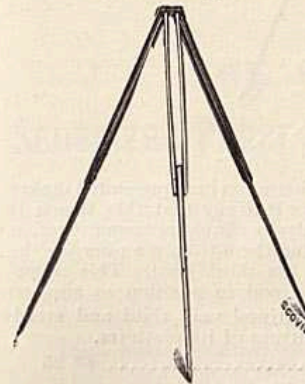

THE IMPROVED TAYLOR TRIPOD.

The illustration here presented makes an extended description unnecessary. Suffice it to say that this tripod is very firm when set up, and folds up compactly by simply pressing together the two upper joints of each leg, thus unsetting them from the pins on the brass top and then doubling them over on to the third joint. This movement is naturally reversed when placing the tripod in position to support the camera.

Price, with metal disc and non-detachable screw.....\$2.25 each.
Adapted for cameras from 1-4 to 8x10 size.



The Daisy Tripod.

An inspection of one of these Tripods will convince the most skeptical that it has no superior for ease of adjustment, lightness and compactness.

Length, when folded, 16½ inches.

Weight, 2 lbs.

Price, \$5.00.

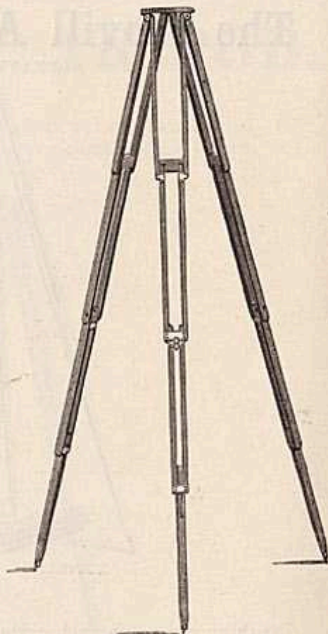
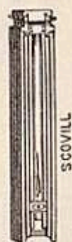

The Taylor Tripod.



This tripod is of English origin. The illustration here presented makes an extended description unnecessary. Suffice it to say that this tripod is very firm when set up, and folds up compactly by simply pressing together the two upper joints of each leg, thus unsetting them from the pins on the brass top and then doubling them over on to the third joint. This movement is naturally reversed when placing the tripod in position to support the camera. The brass circle top makes the tripod very rigid and steady when clamped to a camera, and prevents marring of its platform.

Price, each..... \$2 25

Adapted for cameras from 1-4 to 8 x 10 size.

Patent Camera Reversing Attachments.

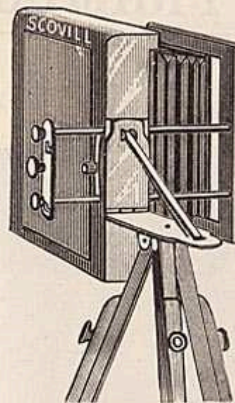

ADAPTED ONLY TO SCOVILL EXTENSION TRIPODS.

No. 1, with No. 1 Extension Tripod, and Camera Bed Plate..... \$4 50

No. 2, with No. 2 Extension Tripod, \$5 00

"When the means for the reversal of a camera are brought into notice, it is a fair test to ascertain how quickly the movement can be consummated; is the mechanism intricate or the reverse; and, finally, does it aid in picture-taking, or, per contra, impair the worth of the production.

"When the new reversing attachment devised at the American Optical Co.'s factory is seen, no manual of instruction need be consulted to ascertain how it is applied or worked. This is obvious. A cut does not convey an idea of its merit thus readily.

"Two brass plates, hinged at the end, are opened to form a right angle, and held rigidly in that position, or are brought together and tightly clamped by a rod with a hooked end, which plays through an opening in the brass plate secured fast to the tripod top. Upon the upper plate the camera is set or unset at pleasure. Whether in the vertical or horizontal position, the camera is held so firmly as to be secured against vibration. The reversal can be effected in an instant."

THE HALLENBECK

Sensitized Paper and Dry Plate Safety Box.

Size.	Price, Ordinary.	Price, Cedar lined.
4 x 5	\$1 00	\$1 50
5 x 8.....	1 15	1 65
6½ x 8½.....	1 25	1 75
8 x 10.....	1 50	2 00
20 x 24.....	4 50	5 50

These boxes are provided with lock and key, and with weighted inside lid to keep paper flat.

IRVING PRINTING FRAMES

(PATENTED.)

The IRVING FRAMES have valuable features which cannot be copied. They are in workmanship, design, and other respects, superior to all other printing frames.

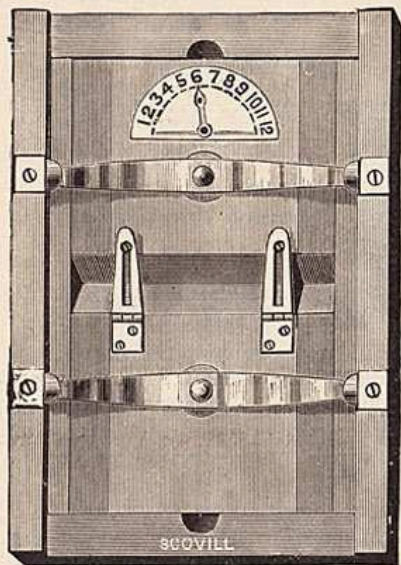

IRVING PRINTING FRAME, CLOSED.
FRONT VIEW.

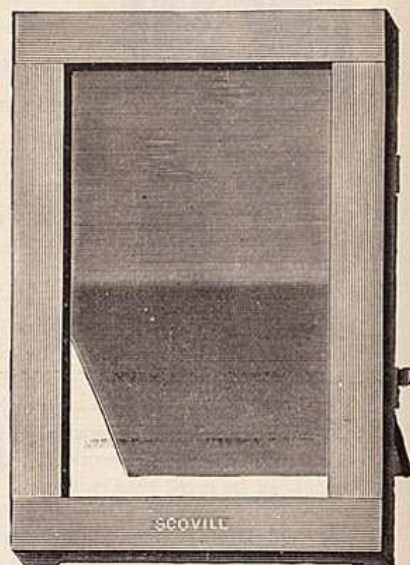

IRVING PRINTING FRAME, OPEN.
BACK VIEW.

The continuous felt pads made especially to order for us, insure absolute protection and uniform pressure throughout. The Irving Patent Catches lock the back, so that when one flap is open there is not the slightest danger of the flaps, paper or negative slipping.

The springs are cut by dies of specially tempered and tested metal, and are riveted to the backs with washers underneath to protect the wood-work.

The IRVING FRAMES are made of cherry guaranteed not to warp or crack. Their construction and finish is acknowledged to be superior to that of all other printing frames.

The tally does not depend upon any other part of the frame to lock it, for the pointer will remain in place no matter what is done to other parts of the frame.

Prices for Half or Two-thirds Opening Styles.

3½ x 4¼.....	.45	6¼ x 8¼.....	.70
4 x 5.....	.48	8 x 10.....	.80
4¼ x 5½.....	.50	10 x 12.....	1.10
4¼ x 6½.....	.55	11 x 14.....	2.10
5 x 7.....	.60	13 x 16.....	2.30
5 x 8.....	.65	14 x 17.....	2.70

When made with backs to open lengthways, ten per cent. is added to the foregoing prices, for the respective sizes.

NEGATIVE BOXES.

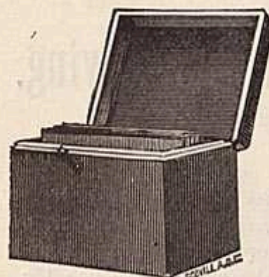

FOR HOLDING
TWENTY-FOUR PLATES
EACH.

	Regular, with Hook.	Light Tight, with Lock and Key.		Regular, with Hook.	Light Tight, with Lock and Key.
3½ x 4¼.....	\$0 62	\$1 62	4 x 8.....	\$0 75	\$1 75
4 x 5.....	65	1 65	5 x 7.....	85	1 85
4¼ x 5½.....	70	1 70	5 x 8.....	90	1 90
4¼ x 6½.....	75	1 75	6½ x 8½.....	1 00	2 00
4 x 7.....	75	1 85			

LANTERN SLIDE BOXES.

No. 1, to hold 25 Lantern Slides.....	\$ 65
" 2, " 50 " ".....	1 30
" 3, " 100 " ".....	2 50

SCOVILL DEVELOPING BOTTLE,

For Holding

Stock Solutions.

EITHER

Ferrous Oxalate Developer



Or Carbonate of Soda used

with Pyro Developer.

SUPPLIED WITH PURE CLOTH RUBBER TUBING (GUARANTEED).

Bottle to hold one pint of solution.....	each,	\$0 60
" " one quart ".....	"	75
" " two quarts ".....	"	1 00
" " one gallon ".....	"	1 25

LABEL WITH DIRECTIONS FOR USE ON EACH BOTTLE.

✻ RUSSELL ✻

Negative Clasp and Rack for Drying.

By using the **Russell Negative Clasp and Rack for Drying**, there is no need of wetting or staining the fingers in the developer, or of touching a plate until after it has been developed, varnished and dried. Adaptable for all sizes, from $3\frac{1}{4} \times 4\frac{1}{4}$ to 8×10 inclusive. Price, 15c. each.

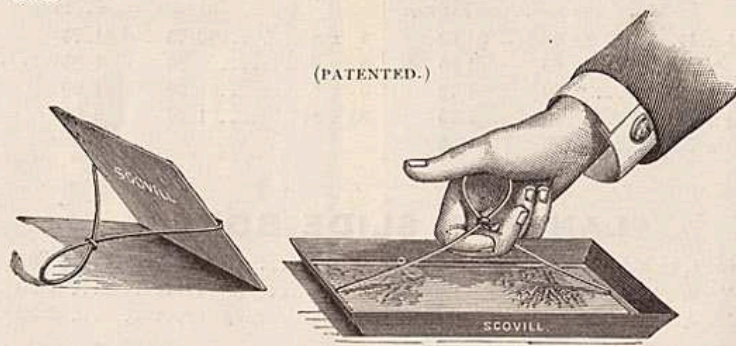

Scovill's Efficient Plate Lifter.

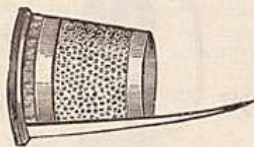

This Plate Lifter is very nearly like an ordinary open end **Thimble** with a **Pointed piece of Metal** soldered securely to it, as shown in the illustration.

Where a number of plates are developed in one dish, this Plate Lifter is not only a convenience, but quite a necessity.

Being the largest makers of Thimbles in the country, we are enabled to offer these Plate Lifters for the nominal price of 15 cents each.

The SCOVILL PEERLESS DARK-ROOM LANTERN.

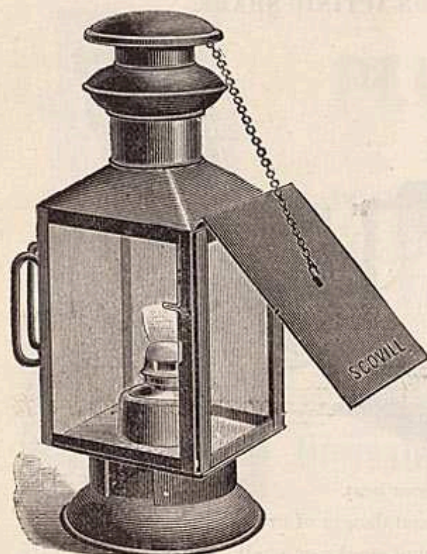

"This is without question the best Lantern for the photographers' use yet introduced." Such is the report of experts who have had them in use for months.

Why they were agreed in their conclusions :

Because the ventilation is perfect, and danger of overheating overcome.

Because it is constructed so that white light does not escape.

Because it gives ample light for the dark-room.

Because the abundant light does not fog, but does show any spot or blemish in the plate.

Because so much of the light may be thrown into the developing dish and be shaded from the eyes.

Because it may be used either with coal oil or candle.

Because the flame may be so quickly controlled by unlatching the door or uncatching the bottom of the Lantern.

Price, \$2.50.

The W. I. A. Petite Dry-Plate Lantern

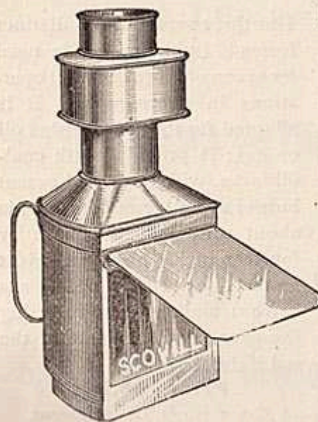

Will be found quite superior to any lantern previously offered at a smaller price than the Scovill Peerless Lantern. It is much to be preferred above an oil consumer, on account of safety and cleanliness. The light emitted is abundant, and the ventilation perfect. When not in use the chimney of this petite lantern may be taken off and placed inside over the candle.

Price, \$1.25.

The Scovill Electric Dark Room Lamp. WITH NON-ACTINIC SHADE.

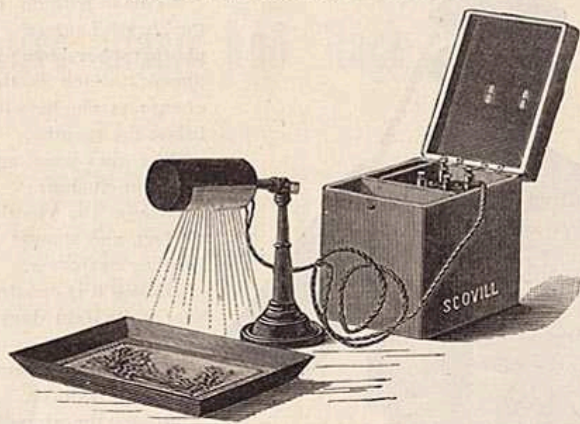

Good features
never before
combined for
the dark room.

Light without heat.
Light without danger of fire.
Light without smoke or smell.

Pure air
and ventilation
for
the dark room.

Three candle-power Lamp.....\$7.00
" " " " with Switch..... 8.00

CARBUTT'S Multum in Parvo Dry Plate Lantern.

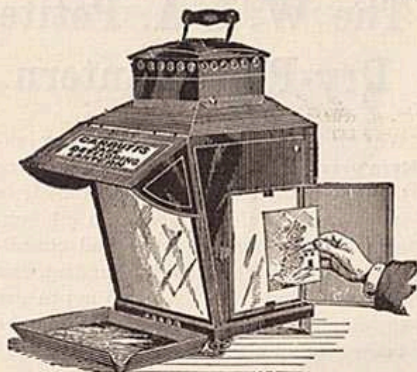

Lantern arranged for developing, and after fixing
examining negatives by opal light.

Has three separate and distinct forms of light, and can be used for seven or more different operations in photography. It is adapted for the use of either oil or gas; is provided with coal-oil lamp, with improved patent burner and silvered reflector; is about nine inches square by fourteen inches high, with eight by ten light of deep ruby glass in front, and good for protecting the eyes from the glare of the red light.

Price, \$6.00.

Boxed ready for shipment.

A Great Convenience in Developing Dry Plates.



PELLETONE PYROGALLIC ACID TABLETS

Put up in bottles, each containing 100
two-grain (exactly 2 grains) tablets of

SCHERING'S
Unrivalled Pyrogallic Acid.

Price per Bottle 40 Cents.

S. P. C. CARBONATE SODA DEVELOPER,

Price per Package, 50 Cents.

S. P. C. Pyro and Potash Developer,

Price per Package, 60 Cents.

" " Pint Set, \$1.25.

" " Quart Set, \$2.25.

Do not Stain the Fingers or Leave the Plate Yellow.

WORK EQUALLY WELL WITH ALL BRANDS
OF PLATES.

Giving perfect detail, density and brilliancy in the negative.

Full directions enclosed in each package.

S. P. C. Bromide Developer, for Eastman Bromide Paper,

Price, 75 Cents.

DEVELOPERS AND CHEMICALS IN SOLUTION

TRANSPORTED SAFELY IN

CORRUGATED PROTECTING CASES,

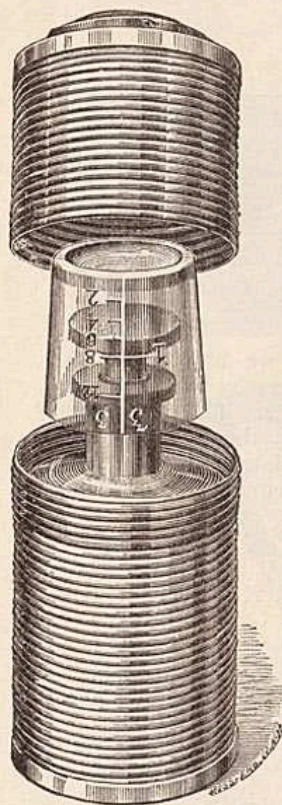

Supplied with Cut Glass Bottles, and Graduated Tumbler to Measure Liquids.

CORRUGATED PROTECTING CASES are a great convenience to the landscape Photographer and amateur picture-taker when away from home. Though made of thin metal, the corrugation makes them so strong as to resist crushing. Being nickled and finely finished, the external appearance of these Cases is

DECIDEDLY TASTEFUL,

indeed, one would be more inclined to place them in a satchel than in a packing case. Whether carried about in a horizontal or vertical position, the locking ring affords perfect protection for the liquids contained in the bottle.

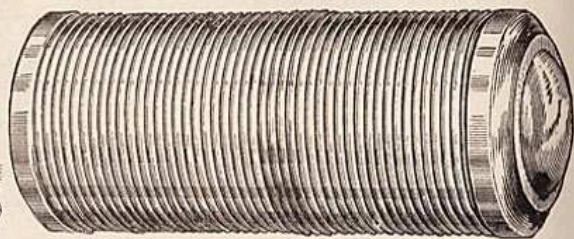

PRICE LIST.

	Each.
No. 1. Diameter, 1½ in. Length, 3½ in. Weight, 4½ oz. Furnished with 1 ounce bottle.....	\$.50
No. 3 A Diameter, 2 in. Length, 5½ in. Weight, 7½ oz. Furnished with 4 oz. bottle, with tumbler, making ½ pint flask.....	.85
No. 4 A Diameter, 2½ in. Length, 7 in. Weight, 14 oz. Furnished with 8 oz. bottle, with tumbler, making ½ pint flask.....	1.10
No. 13 A Diameter, 2½ in. Length, 6 in. Weight, 17 oz. Furnished	

TRANSPARENCIES.

DRAWING-ROOM TRANSPARENCY FRAMES.

These Frames can be described, or characterized by one phrase, "THE REFINEMENT OF TASTE."

SIZE	EACH.	SIZE.	EACH.
4 x 5 inch.....	\$0 28	6½ x 8½ inch.....	\$0 38
4½ x 6½ ".....	30	6½ x 9 ".....	48
5 x 7 ".....	30	8 x 10 ".....	48
5 x 8 ".....	34	10 x 12 ".....	75
6½ x 7½ ".....	38	11 x 14 ".....	90



CARBUTT'S KEYSTONE TRANSPARENCY PLATES.

SCOVILL'S ETCHED GROUND GLASS

(WITH HANDSOME DESIGNS ON BORDER), FOR TRANSPARENCIES.

6½ x 7½ for 4 x 5 Picture.....	Per light, 27½ cts.
6½ x 9 " 4½ x 6½, 5x7, and 5x8 Picture.....	" 42½ "
8 x 10 " 6½ x 8½ Picture.....	" 50 "
10 x 12 " 8 x 10 ".....	" 62½ "

Plain Ground Glass for Transparencies.

	Per Light.		Per Light.		Per Light.
4 x 5.....	\$0.12	5 x 8.....	\$0.18	8x10.....	\$0.35
4½ x 5½.....	15	6½ x 8½.....	28	10x12.....	50
4½ x 6½.....	16				

Scovill's Outfit for Making Lantern Slides consists of

- 1 doz. Thin Crystal Glass.
- 2 " Black Mats.
- 1 package Black Adhesive Paper.
- 1 doz. 3¼x4 Keystone Gelatino-Albumen Dry Plates.
- 1 package S. P. C. Pyro and Potash Developer.
- 2 4¼x5½ Solid Glass Pans.
- 1 lb. Hyposulphite Soda.

The above, packed in wooden case, price complete..... \$3 50

For enlarging, reducing, or copying Negatives to make Lantern Slides, we recommend the use of one of the Scovill Enlarging, Reducing and Copying Cameras.

SCOVILL'S GLOSSY RUBBER TRAYS.

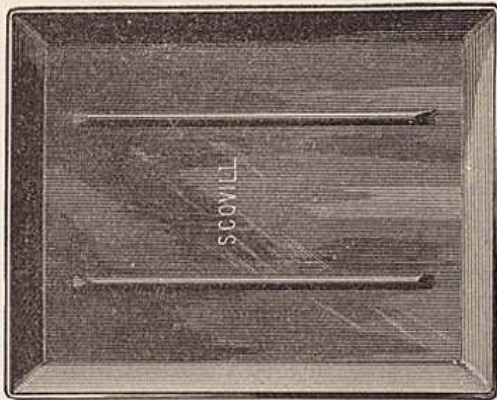

After a protracted and costly series of experiments, we are now able to offer to the trade, a superior article in texture, durability and polish. The utility of the parallel ridgelets must at once be apparent to the photographic practitioner.

PRICE LIST.

No.	Size.	Price, each.
No. 200,	4¾ x 5½ for 1-4, 4-5, and 4½ x 5½ plates.....	\$0 28
" 300,	5½ x 8½ for 5 x 7 and 5 x 8 "	56
" 400,	7 x 9 for 6½ x 8½ "	72
" 500,	8½ x 10½ for 7 x 9 and 8 x 10 "	1 08

**The ADT PATENT
PRINT MOUNTER.**

**THIS IMPROVEMENT SIMPLIFIES THE MOUNTING
OF PHOTOGRAPHIC PRINTS.**

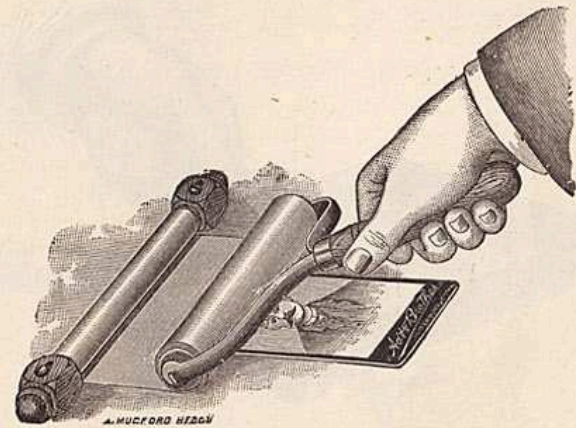

The Adt Patent Print Mounter

Consists of a spring roller, to which is attached a handle, and upon which is wound a band of fine cotton cloth, one end of the band being fastened to a rod which is screwed to the mounting table.

After the pasted print has been placed upon the mount, the roller is drawn over the print, as shown in the cut, the spring roller drawing the cloth band perfectly tight, and re-winding it when the roller returns.

The uniform pressure of the roller removes all the air from under the print and presses it securely to the mount.

It absorbs the moisture from the surface of the print, leaving it perfectly smooth.

It will not displace the print, the roller being held in place by the tension of the spring on the band.

The band is of sufficient length so that when, in time, a portion of it becomes soiled, it can be wound upon the removable rod, which is fastened to the table, thereby exposing a clean surface.

When the entire band becomes soiled it may be removed, washed, and replaced.

The ADT MOUNTER is made in a substantial manner.

It saves a vast amount of time and labor, and does the work better than by any other method.

Price, each, - - - - - \$1.80.

THE ADT Patent Manipulator.

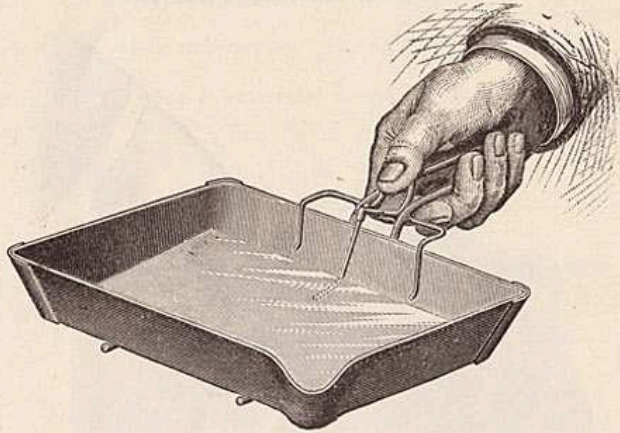

The combined features of this Device make it an indispensable contrivance for the Dark-Room.

ADAPTABLE FOR VARIOUS SIZE TRAYS.

As will be seen by a glance at the cut, this device not only protects the hands in lifting the plate from the developer, but as they do not come in contact with the tray, stained fingers are entirely avoided.

It not only prevents soiling the hands, but will be found a great aid in manipulating the plate.

It is attachable to and will firmly hold various sizes and depths of trays without adjusting.

The lifter is of German Silver, flattened at the end, thus requiring no extra amount of developer.

They are strongly made and heavily nickel-plated throughout.

Price, 85 Cents Each.

—S. P. C.—
JAPANNED DEVELOPING TRAYS

(Made of Selected Metal)

—FOR—

DRY PLATE PHOTOGRAPHY.

Size $4\frac{1}{2}$ x $5\frac{1}{2}$ inches.....	price each, 20 cents.
" $5\frac{1}{2}$ x $8\frac{1}{2}$ "	" 25 "
" 7 x 9 "	" 30 "
" $8\frac{1}{2}$ x $10\frac{1}{2}$ "	" 40 "

BURNISHERS.

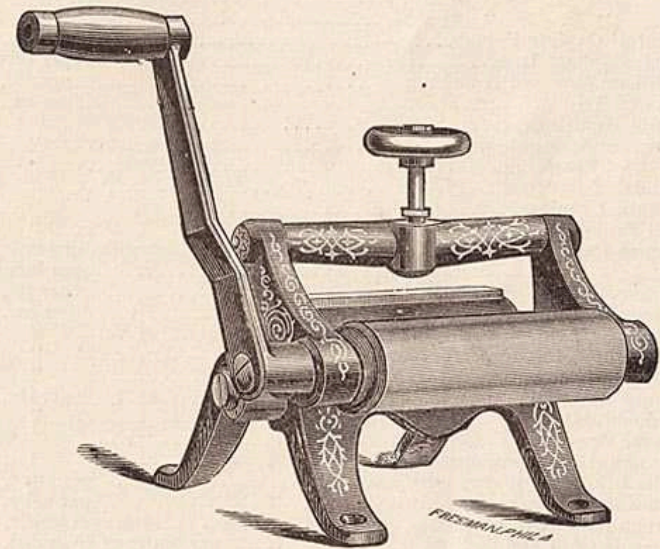

—PRICES—

6 inch roll.....\$13 00 | 10 inch roll.....\$20 00

If by accident, or otherwise, the burnishing tool becomes defaced, it can be replaced with a new tool at a mere nominal cost, and the machine is as good as new.

GENERAL PRICE LIST.

Chemicals subject to Fluctuation in Prices.

Glass Forms, Stereo.....each, \$0 40	Glass Forms, 4 x 5.....each, \$0 50
Card Glass Forms..... " 25	" 5 x 8..... " 1 00
Cabinet " " " 50	" 6 1/4 x 8 1/4..... " 1 25
Robinson's Straight Trimmers..... " 50	
" Revolving " with guide..... " 1 00	
Scovill Focusing Cloths..... " 50	
Printing Frames, flat, 3 1/4 x 4 1/4..... " 36	
" " 4 x 5..... " 38	
" " 4 1/4 x 5 1/4..... " 40	
" " 4 1/4 x 6 1/4..... " 42	
" " 5 x 7..... " 50	
" " 5 x 8..... " 52	
" " 6 1/2 x 8 1/2..... " 60	
Neutral Oxalate Potash.....per lb., 40	
Protosulphate Iron.....per box, 10	
Sulphate Iron and Ammonia.....per lb., 18	
Oxalic Acid.....per oz., 10	
Citric Acid....." 15	
Bromide Ammonium....." 12	
" Potassium....." 10	
Iodide "....." 30	
Nitrate Uranium....." 90	
Red Prussiate Potash....." 10	
Litmus Paper.....per sheet or book, 5	
" ".....per box, 50	
Carbonate Soda (Sal Soda).....per lb., 10	
Pyrogallic Acid.....per oz., 40	
Sulphuric Acid, in bottle and tin can....." 20	
Bichloride Mercury....." 15	
Chloride Ammonium....." 10	
Liquid Ammonia, conc.....per lb., 32	
Hyposulphite Soda....." 10	
Alum, Powdered....." 10	
Chrome Alum (commercial) in box....." 20	
India Ink (for stopping out).....per stick, 25	
Gihon's Opaque.....per cake, 50	
French Azotate (for toning).....per bottle, 25	
Chloride Gold and Sodium.....per bottle of 15 grains, 35	
" " " " " 30 " 55	
S. P. C. Negative Varnish.....per bottle, 35	
Parlor Paste (for mounting pictures).....1/2 pint jar, 25	
" " " " " pint bottle, 35	
" " " " " quart jars, 65	
Acetate Soda.....1/4 lb. bottles, 15	
Ground Glass Substitute.....per bottle, 50	
Dropping Tubes.....each, 10	
W. I. A. Petite Lantern....." 1 25	
Peerless Lanterns....." 2 50	

CARBUTT'S

Keystone Dry Plates.

The Renowned KEYSTONE DRY PLATES are coated on personally im- ported fine English glass—flat and accurately cut.	SPECIAL INSTANTANEOUS (blue label) for Portraits and Drop Shutter Views. And "B" white label, for Landscape and General Photography.	STRIPPING PLATES, For Engravers and Photo- Mechanical Reproductive pro- cesses.	Orthochromatic and GELATINO-ALBUMEN Transparency Plates.	GELATINO-ALBUMEN, on fine Ground Glass, for Win- dow and Door Transparencies.	Gelatio-Albumen on bright surface OPAL, for Contact and Enlarging.	Gelatio-Albumen on fine Matt surface OPAL, for water or oil color painting.
	Dozen.		Dozen.	Dozen.	1/2 Dozen.	1/2 Dozen.
3 1/4 x 4 1/4	Thin Crystal Lantern Slides.	Glass for Slides.	\$0 65
3 1/4 x 4 1/4	\$0 45	\$0 60	55	\$0 70	\$0 45	\$0 55
4 x 5	65	90	80	1 00	65	80
4 1/4 x 5 1/2	75	90	1 12	75	90
4 1/4 x 6 1/2	90	1 20	1 08	1 35	90	1 12
4 3/4 x 6 1/2	95	1 20
5 x 7	1 10	1 45	1 40	1 75	1 10	1 35
5 1/2 x 7	1 25	1 65	1 50
5 x 8	1 25	1 65	1 50	1 90	1 25	1 55
6 1/2 x 8 1/2	1 65	2 20	2 00	Doz. 2 60 1/2 Doz. 1 35	1 65	2 05
8 x 10	2 40	3 20	3 00	Doz. 3 75 1/2 Doz. 1 90	2 40	3 00
10 x 12	3 80	5 05	4 50	1/2 Doz. 2 80	3 80	4 75
11 x 14	5 00	6 65	5 85	1/2 Doz. 3 60	5 00	6 25
14 x 17	9 00	12 00	10 80	1/2 Doz. 6 75	9 00	12 00
16 x 20	12 50	16 65
17 x 20	13 00	17 30
18 x 22	15 50	20 00
20 x 24	18 50	24 50

SIZES 10 X 12 AND LARGER ARE PUT UP HALF DOZEN IN A BOX.

INSTRUCTIONS AND FORMULA FOR
KEYSTONE

CARBUTT'S  DRY PLATES.

SPECIAL PORTRAIT AND INSTANTANEOUS.

Blue Label; Sensitometer 23 to 25.

PRONOUNCED THE NE PLUS ULTRA OF DRY PLATES.

B—Landscape and Copying. A—Gelatio-Albumen for Transparencies.

White Label; Sens'r 16 to 20.

Red Label; Sens'r 12 to 14.

ORTHOCHROMATIC PLATES, Normal Sens'r 20 and 25; Color Sens'r 30 and 40.

No. 1. PYRO SOLUTION.

Distilled or Ice Water.....10 oz.
Sulphite of Soda Crystals.....4 oz.
Dissolve and add slowly.
Sulphuric Acid.....1 drachm.
Pyrogallie Acid, Schering's.....1 oz.
And Water to make 16 oz. fluid.

No. 2. ALKALINE SOLUTION.

Water, Distilled, or Melted Ice.....10 oz.
Granulated Carbonate of Soda.....2 oz.
Granulated Carbonate of Potash.....1 oz.
Yellow Prussiate of Potash.....1 oz.
Dissolve, add Water to make measure 16 oz.

[During Hot Weather, add to No. 1, 20 grains Bromide of Potassium.]

BROMIDE SOLUTION.—Bromide Potass. 1 part, Water 9 parts.

TO DEVELOP.

For Portraits on "Special Instantaneous," to 4 ounces of water add 3 drachms No. 1, and 2 drachms No. 2, and if plate has had proper exposure, the above developer will be found to yield a soft and rich printing negative. More of No. 2 to be added if under-exposed, and more of No. 1 with a few drops of Bromide Solution if over-exposed.

For Landscapes and Interiors on "Specials," where the exposure may be uncertain, lay the exposed plate in the Pyro Solution for a minute or two, then into the developing glass put half the quantity of No. 2 as has been taken of No. 1, and pour the Pyro Solution into it, and back on to the plate. By proceeding in this manner, adding more of No. 2 to bring out the image, or a few drops of a 10 per cent. solution of bromide to restrain, as may be required, much better results may be looked for than if a full quantity of No. 1 and No. 2 were mixed at once. FOR INSTANTANEOUS VIEWS or very dark interiors, we recommend the following procedure: To 4 ounces water add 1 dram No. 2, soak plate in this while preparing the following: water, 3 ounces, of Nos. 1 and 2 each 3 drams, 5 drops Bromide Solution, pour off the dilute alkali, and flow this strong developer over the plate; be careful to expose the plate as little as possible to the light used to develop by, no matter how safe it may be considered for ordinary development. Do not hurry by adding more No. 2; cover up the pan and give the developer time to act, when more of No. 1 or No. 2 may be added as required. FOR INSTANTANEOUS MARINE VIEWS, it will be best to treat the plate same as for Landscapes, by soaking plate in Pyro Solution first.

For Landscape, Machinery, Architecture, &c., on B plates, use $\frac{1}{2}$ drachm each Nos. 1 and 2 to each ounce water, adding more of each as may be required. No. 1 giving density, No. 2 giving detail and hastening development.

After washing off developer, immerse in following:

HARDENING AND CLEARING SOLUTION.

Water..... $\frac{3}{8}$ oz. | Citric Acid..... $\frac{1}{4}$ oz.
Chrome Alum..... $\frac{1}{2}$ oz.

3 to 5 minutes, then wash and place in the

FIXING SOLUTION.

Hyposulphite of Soda.....8 oz. | Water.....40 oz.

LANTERN TRANSPARENCIES

AND HOW TO MAKE THEM.

The requisities are, a deep printing frame a size larger than the negative to be used, with a flat glass bottom clear and free from scratches (crystal plate is best), a Carbutt Multum in Parvo Lantern, or other artificial light, and Keystone Gelatino-Albumen Plates. Transparencies can be made same size of negative by contact and exposure to artificial light, or enlarged or reduced in the camera by daylight, with equal perfection in result. To make Lantern Slides by contact, place one of the Keystone thin crystal glass transparency plates over the negative in printing frame, lay piece of dark soft material over it, close down the back, and expose to the clear light side (by opening the left hand door) of a Multum in Parvo Lantern or other light, for 10 to 30 seconds, according to density of negative, at a distance of 20 inches from the flame. Use the following developer:

CARBUTT'S IMPROVED DEVELOPER FOR TRANSPARENCIES.

A.

Oxalate of Potash.....8 oz.
Water.....30 oz.
Citric acid.....60 gr.
Citrate of ammonia solution.....2 oz.

B.

Sulphate of iron.....4 oz.
Water.....32 oz.
Sulphuric acid.....16 drops.

C.

Citrate of ammonia solution.

Dissolve 1 oz. citric acid in 5 oz. distilled water, add liquor ammonia until a slip of litmus paper just loses the red color, then add water to make the whole measure 8 oz.

DEVELOPER.—Add 1 oz. of B to two of A, and $\frac{1}{4}$ oz. of water, and 3 to 6 drops of bromide solution.

Let the development continue until the blacks look quite strong, and detail plainly showing in the high lights; wash off developer thoroughly before fixing, use fresh hypo solution, when fully cleared wash for half hour, then immerse five minutes in the Hardening Solution given below; afterwards wash for half hour, then carefully go over surface with soft camel's-hair brush, or pledget of cotton to remove any particles of dirt; place in rack to dry. Then varnish with plain Collodion:

COLLODION VARNISH.

Alcohol.....4 oz. | Sulphuric ether.....4 oz.
Pyroxyline.....30 to 40 gr.

When, after shaking, the cotton is dissolved, filter and flow the plain Collodion over the dry transparency, the same as when using varnish; when dry, cover with matt and a crystal cover glass, and bind with binding strip.

HARDENING AND CLEARING SOLUTION.

Water..... $\frac{3}{8}$ oz. | Citric acid..... $\frac{1}{4}$ oz.
Chrome alum..... $\frac{1}{2}$ oz.

3 to 5 minutes, then wash and place in the

FIXING SOLUTION.

Hyposulphite of soda.....8 oz. | Water.....40 oz.

Scovill's Complete Photographic Series.

	Price, Per Copy.
No. 1.—THE PHOTOGRAPHIC AMATEUR.—By J. TRAILL TAYLOR. A Guide to the Young Photographer, either Professional or Amateur. (Second Edition.) Paper covers, 50 cents. Library Edition.....	\$1 00
No. 2.—THE ART AND PRACTICE OF SILVER PRINTING.—By H. P. ROBINSON and Capt. W. DE W. ABNEY, R.E., F.R.S. (Third Edition.) Paper covers, 50 cents. Library Edition.....	75
No. 3.—Out of print.	
No. 4.—HOW TO MAKE PICTURES.—By HENRY CLAY PRICE. (Fourth edition.) The ABC of Dry-Plate Photography. Paper covers, 50 cents. Library Edition.....	75
No. 5.—PHOTOGRAPHY WITH EMULSIONS.—By CAPT. W. DE W. ABNEY, R.E., F.R.S. A treatise on the theory and practical working of Gelatine and Collodion Emulsion Processes. (Second Edition.).....	1 00
No. 6.—No. 17 has taken the place of this book.	
No. 7.—THE MODERN PRACTICE OF RETOUCHING.—As practiced by M. Piguepé, and other celebrated experts. (Third Edition).....	25
No. 8.—THE SPANISH EDITION OF HOW TO MAKE PICTURES.—Ligeras Lecciones sobre Fotografia Dedicados a Los Aficionados.....	1 00
No. 9.—TWELVE ELEMENTARY LESSONS IN PHOTOGRAPHIC CHEMISTRY.—Presented in very concise and attractive shape. (Second Edition.)	25
No. 10.—Out of print.	
No. 11.—Out of print.	
No. 12.—HARDWICH'S PHOTOGRAPHIC CHEMISTRY.—A manual of photographic chemistry, theoretical and practical. Ninth Edition. Edited by J. TRAILL TAYLOR. Leatherette Binding.....	2 50
No. 13.—TWELVE ELEMENTARY LESSONS ON SILVER PRINTING. (Second Edition).....	50
No. 14.—ABOUT PHOTOGRAPHY AND PHOTOGRAPHERS.—A series of interesting essays for the studio and study, to which is added European Rambles with a Camera. By H. BADEN PRITCHARD, F.C.S.....	50
No. 15.—THE CHEMICAL EFFECT OF THE SPECTRUM.—By DR. J. M. EDER.....	25
No. 16.—PICTURE MAKING BY PHOTOGRAPHY.—By H. P. ROBINSON. Author of Pictorial Effect in Photography. Written in popular form and finely illustrated. Paper covers, 75 cents. Library Edition.....	1 00
No. 17.—FIRST LESSONS IN AMATEUR PHOTOGRAPHY.—By PROF. RANDALL SPAULDING. A series of popular lectures, giving elementary instruction in dry-plate photography, optics, etc. (Second Edition.) Paper covers, 25 cents. Library Edition.....	1 00
No. 18.—THE STUDIO: AND WHAT TO DO IN IT.—By H. P. ROBINSON. Author of Pictorial Effect in Photography, Picture Making by Photography, etc. Paper covers, 75c. Library Edition.....	1 00
No. 19.—THE MAGIC LANTERN MANUAL.—(Second edition.) By W. I. CHADWICK. With one hundred and five practical illustrations; cloth bound.	75
No. 20.—DRY PLATE MAKING FOR AMATEURS.—By GEO. L. SINCLAIR, M.D. Pointed, practical, and plain. Leatherette binding.....	50
No. 21.—THE AMERICAN ANNUAL OF PHOTOGRAPHY AND PHOTOGRAPHIC TIMES ALMANAC FOR 1887.—(Second Edition.) 50 cents; (postage, ten cents additional.) Library Edition.....	1 00
No. 22.—PHOTOGRAPHIC PRINTING METHODS.—By the Rev. W. H. BURBANK. A Practical Guide to the Professional and Amateur Worker. Cloth bound.....	1 00
No. 23.—A HISTORY OF PHOTOGRAPHY: Written as a Practical Guide and an Introduction to its Latest Developments, by W. JEROME HARRISON, F. G. S., and containing a frontispiece of the author. Cloth bound.....	1 00
No. 24.—THE AMERICAN ANNUAL OF PHOTOGRAPHY AND PHOTOGRAPHIC TIMES ALMANAC FOR 1888.—Illustrated—Paper, 50 cents; (when by mail, ten cents additional.) Library Edition.....	1 00
No. 25.—THE PHOTOGRAPHIC NEGATIVE.—A Practical Guide to the preparation of sensitive surfaces by the calotype, albumen, collodion, and gelatine processes, on glass and paper, with supplementary chapter on development, etc., by the Rev. W. H. BURBANK. Cloth bound.....	1 50

SOME OTHER Photographic Publications.

Selected from Scovill's Catalogue of Books.

	Price, Per Copy.
ART RECREATIONS.—A guide to decorative art. Ladies' popular guide in home decorative work. Edited by MARION KEMBLE.....	\$2 00
THE FERROTYPERS' GUIDE.—Cheap and complete. For the ferrotypist, this is the only standard work. Seventh thousand.....	75
THE PHOTOGRAPHIC STUDIOS OF EUROPE.—By H. BADEN PRITCHARD, F.C.S. Paper, 50 cts.; Cloth.....	1 00
PHOTOGRAPHIC MANIPULATION.—Second edition. Treating of the practice of the art and its various applications to nature. By LAKE PRICE.....	1 50
HISTORY AND HAND-BOOK OF PHOTOGRAPHY.—Translated from the French of Gaston Tissandier, with seventy illustrations. Cloth.....	2 50
AMERICAN CARBON MANUAL.—For those who want to try the carbon printing process, this work gives the most detailed information. Cloth.....	2 00
MANUAL DE FOTOGRAFIA.—By AUGUSTUS LE PLONGEON. (Hand-Book for Spanish Photographers.) Reduced to.....	1 00
SECRETS OF THE DARK CHAMBER.—By D. D. T. DAVIE.....	1 00
THE PHOTOGRAPHER'S GUIDE.—By JOHN TOWLER, M.D. A text-book for the Operator and Amateur.....	1 50
A COMPLETE TREATISE ON SOLAR CRAYON PORTRAITS AND TRANSPARENT LIQUID WATER-COLORS.—By J. A. BARRHYDT. Practical ideas and directions given. Amateurs will learn ideas of color from this book that will be of value to them. And any one by carefully following the directions on Crayon, will be able to make a good Crayon Portrait.....	50
THE BRITISH JOURNAL ALMANAC FOR 1888.....	50
PHOTO. NEWS YEAR BOOK OF PHOTOGRAPHY for 1888.....	50
CANOE AND CAMERA.—A Photographic tour of two hundred miles through Maine forests. By THOMAS SEDGWICK STEELE. Illustrated.....	1 50
PADDLE AND PORTAGE.—By THOMAS SEDGWICK STEELE.....	1 50
PRACTICAL INSTRUCTOR OF PHOTO-ENGRAVING AND ZINC ETCHING PROCESSES.—By ALEX. F. W. LESLIE.....	50
PHOTO-ENGRAVING on Zinc and Copper in Line and Half-Tone, and PHOTO-LITHOGRAPHY. A Practical Manual, by W. T. WILKINSON. Cloth bound. ...	2 00

SOME PHOTOGRAPHIC REFERENCE BOOKS.

	Price, Per Copy.
AMERICAN HAND-BOOK OF THE DAGUERRETYPE.—By S. D. HUMPHREY. (Fifth Edition.) This book contains the various processes employed in taking Heliographic impressions.....	10
THE NEW PRACTICAL PHOTOGRAPHIC ALMANAC.—Edited by J. H. FITZGIBBON.....	25
MOSAICS FOR 1870, 1871, 1872, 1873, 1875, 1878, 1882, 1883, 1884.....	each, 25
BRITISH JOURNAL ALMANAC FOR 1878, 1882, 1887.....	" 25
PHOTO. NEWS YEAR-BOOK OF PHOTOGRAPHY FOR 1871, 1882, 1887.....	25
THE PHOTOGRAPHER'S FRIEND ALMANAC FOR 1873.....	25

The American Annual of Photography and Photographic Times Almanac for 1888,

C. W. CANFIELD, Editor.

It contains EIGHT (8) full page high-grade illustrations, and over NINETY (90) original contributions, written expressly for its pages, by the most eminent photographic writers of Europe and America.

The ILLUSTRATIONS comprise

- A **PHOTOLITHOGRAPH**, showing an improved new process, by the Photogravure Co. of New York.
 A **PHOTO COPPER-PLATE ENGRAVING** of a Pictorial Landscape Subject, by E. Obernetter, of Munich.
 A **BROMIDE PRINT** of a most artistic subject, by the Eastman Dry Plate and Film Co.
 A **ZINC ETCHING**, from the Engraving, which is itself as fine as an engraving, by Stevens & Morris.
 A **CHARMING CHILD PORTRAIT**, by Crosscup & West's improved process, and
THREE MOSS TYPES of popular subjects. And numerous wood-cuts, diagrams, etc. throughout the letter-press.

The CONTRIBUTIONS are as follows:

- Abnormal Chloride of Silver. Dr. Julius Schnauss.
 A Cry for Simplicity. W. H. Potter.
 Alum in the Hypo Bath. G. Cramer.
 "Amateurs," "Professionals," or "Photographers." Robert S. Redfield.
 Argentometer for Controlling Silver Baths. Dr. E. A. Just.
 A Talk to Beginners. Prof. Charles Ehrmann.
 Blisters in Albumen Prints, The Origin of. W. H. Sherman.
 Bromide Paper, About. Robert Barr (Luke Sharp).
 Camera and a New Tripod-head, A Home-made Tourist. Rev. W. H. Burbank.
 Carbonate of Soda Development for Platinotypes. Joseph B. Brown, U. S. A.
 Collodion Emulsion. C. E. von Sothen.
 Colored Screens in Out-door Photography. E. Bierstadt.
 Composition in Landscape Photography. W. H. Walmsley.
 Carrying-box, A Convenient. Charles E. Willard.
 Copying and Enlarging Closet, A. W. H. Gardner.
 Dark-rooms. Ellerslie Wallace.
 Dark-rooms for Photographic Clubs. F. C. Beach.
 Detective Camera for Newspaper Photography, The. Henry L. Tolman.
 Detective Cameras. W. J. Stillman.
 "Detective" for Artists, The. J. Wells Champney.
 Developer, A Convenient, for Travelers. A. S. Murray.
 Developer, A New. A Russian Amateur.
 Developer, A New. John E. Dumont.
 Does it Pay? G. L. Hurd.
 Durable Sensitized Albumen Paper. Karl Schwier.
 Drying Negatives Quickly. F. A. Jackson.
 Enlarging and Reducing with Ordinary Camera. Frank La Manna.
 "Equivalent Focus," The, Not a Constant. Ernst Gundlach.
 Figure, Landscape, and Combination Printing. H. P. Robinson.
 Focal Adjustment in Detective Cameras. Clarence E. Woodman, Ph.D.
 Focusing. W. H. Bartholomew.
 Frills and Blisters. G. Watmough S. Webster, F. C. S.
 Genre Photography. John Bartlett.
 Heliogravure and Galvanography. Ottomar Volkmer, Lt.-Col.
 High or Low Art. W. I. Lincoln Adams.
 Hypo in the Developer. Rev. G. M. Searle.
 Ink Transfer, A Method of. P. C. Duchochois.
 Iodide of Silver in Gelatino-bromide of Silver Emulsion. Victor Schumann.

- "It's no Jist Ready Yet." T. N. Armstrong.
 Japanese Paper for Photographers. Prof. W. K. Burton.
 Lantern Slides and Transparencies. Geo. L. Sinclair, M. D.
 Large Telescopes for Celestial Photography. Rudolph Spitaler.
 Magnesium Light Experiments. George Mason.
 Marine Shots. Hon. A. A. Adee.
 Memoranda from My Reading and Practice. H. Edwards-Ficken.
 Mixing an Emulsion with Ammonia. Samuel Wadsworth.
 Mounting Silver Prints in Optical Contact with Glass, and Ornamental Borders. W. M. Ashman.
 Musings by the Way. H. McMichael.
 My Dark-room Window. George E. Francis, M. D.
 "My" Developer. C. C. Vevers.
 Objectives for Photo-micrography. Andrew Pringle.
 Observations. E. M. Estabrooke.
 Odds and Ends. W. Jerome Harrison, F.G.S.
 Old Friend, Keep Young. J. F. Ryder.
 On the Character of Optical Glass. Dr. Adolph Steinheil.
 Optical Sensitizers, On the So-called. C. Schiendl.
 Orthochromatic Photography of Paintings. W. J. Baker.
 Orthochromatic Plates, Experiments with. Ed. L. Boissonnas.
 Over-Exposure and the Means to Correct It. John Carbutt.
 Photo-copper-plate Printing and Steel-facing of Etched Copper-plates. E. Obernetter.
 Photographic Chips. J. R. Swain.
 Photographing in Japan. W. H. Metcalf.
 Photographing in the Arctic. Herbert L. Aldrich.
 Photographing Machinery. F. R. C. Perrin.
 Photography by Lamplight. Robt. E. M. Bain.
 Photography in the Navy. Saml. W. Very, Lieut.-Comdr., U. S. Navy.
 Photography of Solar Eclipses, On the. Prof. Wm. Harkness, U. S. Navy.
 Photo-micrographs, A Simple Arrangement for the Production of. Maurice N. Miller, M. D.
 Porcelain Pictures by the Powder Process. J. Traill Taylor.
 Portraits in Imitation of Old Paintings. Prof. Karl Klausner.
 Practical Hints on Obernetter's Method of Copying Negatives. F. Mueller.
 Preparation of Photographic Gun-cotton, On the. Dr. Jos. M. Eder.
 Printing, Suggestions on. Walter S. Goodnough.
 Reproducing Architectural Drawings. J. Albert Cole.
 Results. Abraham Bogardus.
 Retouching Gelatine Negatives with Red Chalk and Black Crayon. Anton Baumgartner.
 Review of the Year. The Editor.
 Reversing the Print. Henry M. Parkhurst.
 Silver Printing.—An Amateur's Experience. W. J. Hickmott.
 Silver Printing, An Amateur's Routine of. Ottomar Jarecki.
 Shutter, A Simple Time and Instantaneous. Hermann Lemp.
 Some Thoughts of an Amateur. N. W. Starbird, Jr.
 Stereopticon Outfit, A Home-made. A. H. Oakes.
 Stereoscopic Pictures. Chas. Wager Hull.
 Tannin Plates for Lantern Slides. J. H. Harvey.
 Temporary Binding for Photographic Journals. Jos. S. Rich.
 Theatre Photograph by Electric Light. Ernest Edwards.
 The Elimination of Heat from Condensed Light. O. G. Mason.
 The Lightning Photographer: A Sketch of the Future. J. Gaedike.
 The Undeveloped Side of Photography. Wendell Stanton Howard.
 Why Study Art? Edward L. Wilson, Ph.D.

The size—royal octavo—and style of binding is uniform with last year's issue, and notwithstanding the cost of preparation the price remains the same.

Paper Covers, - - - 50c. | Library Edition, - - - \$1.00
 By mail, 10c. additional.

THE
American Annual of Photography
 AND
"Photographic Times" Almanac

For 1887.

C. W. CANFIELD, Editor.

A STANDARD BOOK OF REFERENCE.

It contains five full-page illustrations :

AN EXQUISITE PHOTO-GRAYURE, by Ernest Edwards.

A BROMIDE PRINT, by the Eastman Company.

A SILVER PRINT, by Gustav Cramer, of St. Louis.

TWO MOSS TYPES, by the Moss Engraving Company.

197 pages of **Contributed Matter**, consisting of articles on various subjects, by 80 representative Photographic writers of this country and Europe.

Also, in addition to the contributed articles :—Yearly Calendar. Eclipses, the Seasons. Church Days, Holidays, etc. Monthly Calendar, giving Sunrise and Sunset for every day in the year; Moon's phases; also, dates of meetings of all American Photographic Societies. A list of American and European Photographic Societies. Photographic Periodicals, American and European. Books relating to Photography, published 1886. Approved Standard Formulæ for all processes now in general use. Tables of Weights and Measures. American and Foreign Money Values. Comparisons of Thermometric Readings. Comparisons of Barometric Readings. Symbols and Atomicity of the Chemical Elements. Symbols, chemical and common names and solubilities of the substances used in Photography. Tables for Enlargements and Reductions. Equations relating to Foci. Tables of Comparative Exposures. Freezing Mixtures. Photographic Patents issued 1886. Postage Rates. All Tables, Formulæ, etc., brought down to date and especially prepared or revised for this work.

Price, per Copy, 50 Cents. By mail, 10c. extra.
Library Edition, \$1.00. " "

For sale by all dealers, and by the publishers,

SCOVILL MANUFACTURING CO., Publishers.

Wilson's Photographic Publications.

For Sale by the Scovill Manufacturing Co.

	Price, Per Copy.
WILSON'S QUARTER CENTURY IN PHOTOGRAPHY.—By EDWARD L. WILSON, Ph.D. "The best of everything boiled out from all sources." Profusely illustrated, and with notes and elaborate index.....	\$4 00
WILSON'S PHOTOGRAPHICS.—"Chautauqua Edition," with Appendix. By EDWARD L. WILSON, Ph.D. A most complete photographic lesson-book. Covers every department. 352 pages. Finely illustrated.....	4 00
THE PROGRESS OF PHOTOGRAPHY.—By DR. H. W. VOGEL. Revised by Edward L. Wilson, Ph.D. Gives special consideration to Emulsion Photography, and has an additional chapter on Photography for Amateurs. Embellished with a full-page electric-light portrait by Kurtz, and seventy-two wood-cuts.....	3 00
PICTORIAL EFFECT IN PHOTOGRAPHY.—By H. P. ROBINSON. For the art photographer. Cloth, \$1.50; paper cover.....	1 00
BIGELOW'S ARTISTIC PHOTOGRAPHY, with photographs	4 00
HEARN'S STUDIES IN ARTISTIC PRINTING, with photographs.	3 00
BURNET'S ESSAYS ON ART. A <i>fac simile</i> reproduction of the costly original edition.....	4 00
THE PHILADELPHIA PHOTOGRAPHER.—Edited by EDWARD L. WILSON, Ph.D. A semi-monthly magazine, illustrated by photographs. \$5.00 a year; for six months.....	2 50
THE PHOTOGRAPHIC COLORISTS' GUIDE.—By JOHN L. GHON. The newest and best work on painting photographs.....	1 50
WILSON'S LANTERN JOURNEYS.—By EDWARD L. WILSON, Ph.D. In three volumes. For the Lantern Exhibitor. Give incidents and facts in entertaining style of about 3,000 places and things, and travels all over the world. Per volume.....	2 00
PHOTOGRAPHIC MOSAICS, 1888. Published annually. Cloth bound, \$1.00; Paper cover	50

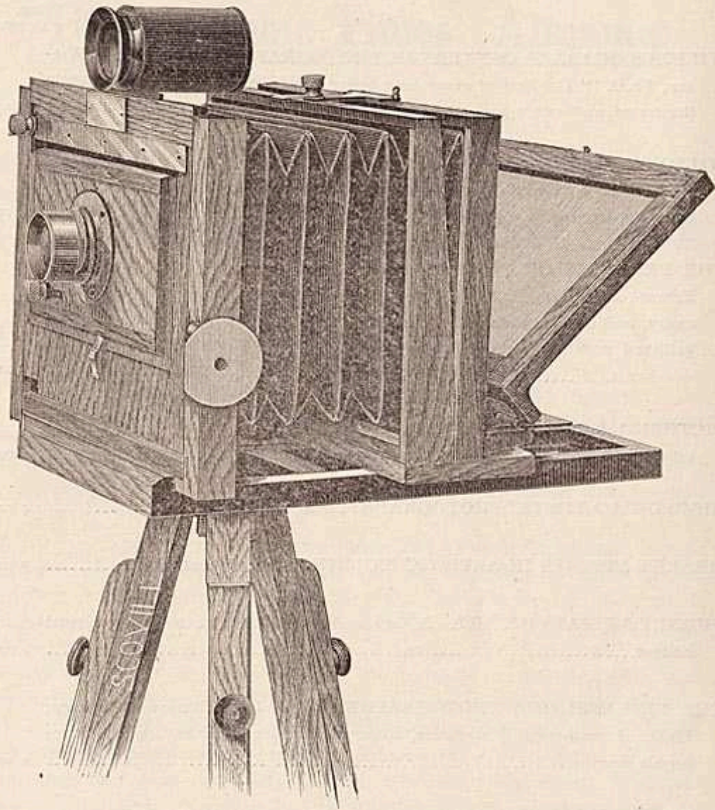

'76 Camera, with Morrison Lens and Waterbury View Finder

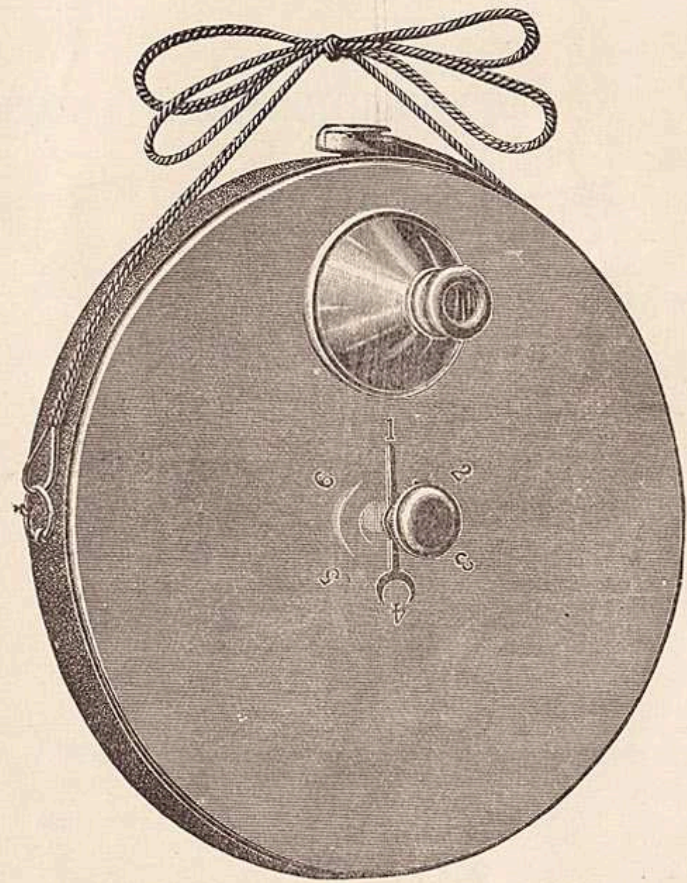

≡Concealed Camera.≡

.....188

SCOVILL MANUFACTURING CO.,

423 BROOME STREET, NEW YORK.

*Please send to address given below, the
issue of the PHOTOGRAPHIC TIMES, commencing with
.....188 , and the AMERICAN ANNUAL
OF PHOTOGRAPHY for 188 , for which enclosed is
\$3.50.*

Name,.....

P. O......

County,.....

State,.....

**NOTE.—Please specify whether Weekly or Monthly edition
is desired.**

INDEX.

	PAGE
A	
"A. B. C." Photo Outfits.....	16
Adt Manipulator	102
Adt Print Mounter	101
American Scholars' Outfits.....	17
Albion Cameras.....	23-26
Accessories for Scovill's Amateur Photo. Outfits.....	67-107
Albums for Photographs.....	68
Adjustable Tripods.....	87
Adjustable Jointed Tripods.....	87
Acme Glass-Bottom Developing Trays.....	96
Adaptable Negative Washing Boxes	97
"American Annual of Photogra- phy" and "Photographic Times Almanac".....	110-112
American Films.....	79
B	
Bicyclists' Outfits	37
Beck Lenses.....	55
Burnishers.....	103
Bromide Developer.....	95
Bromide Copying Paper	77
C	
Cards.....	67
Chemicals and Accessories.....	14, 15
Centennial Outfits.....	22
Concealed Cameras.....	34
Carb. Soda Developer.....	95
Corrugated Protecting Cases.....	98
C. C. H. Focusing Glass.....	62
Carbutt's Keystone Dry-Plates	105, 106
Cameras, Latest Detective.....	32
Cameras, Detective.....	33
Cameras, '76.....	114
D	
Darlot Lenses.....	56
Darlot Gem Lenses.....	56
Daisy Dry-Plate Holders.....	84
Daisy Tripods.....	88
Developing Bottles.....	91
Developing Solutions.....	96
Developing Trays.....	96
Detective Cameras.....	31-33
Developers.....	95
Dry Plates.....	105, 106
Dry-Plate Holders.....	84
Dry-Plate Outfits, Scovill.....	9
Double Holders.....	82
Duplex Photographic Shutter.....	59, 60
E	
Enlarging, Reducing and Copying Cameras	36
Eastman's Permanent Bromide Paper.....	80
Extra Spool Holders.....	63, 64
Extension Tripods.....	85
Efficient Plate Lifter.....	92
Electric Dark-Room Lamps.....	93, 94
Etched Ground-Glass for Trans- parencies.....	99
F	
Focusing Glasses.....	62
Favorite Apparatus Outfits.....	10-12
Film Carriers	64
Films, American.....	79
Ferro-Prussiate Paper.....	75
Flammang's Patent Revolving- Back Camera.....	28, 29
Flammang Single Dry-Plate Holder.....	84, 85
Flandreau's S. P. C. Hypo. Elim- inator	96
Flandreau's S. P. C. Retouching Fluid.....	96
Flandreau's S. P. C. Orthochro- matic Solutions.....	96
Flandreau's Outfits.....	21
Finders.....	61
G	
General Price List.....	104
Gundlach Lenses.....	45, 46
Glossy Rubber Trays.....	100
Glass Bottom Trays.....	96
Ground-Glass.....	99
H	
How to make Photographs.....	1-8
Howard Albums.....	70, 71
Howard Foto-Folios.....	72
Howard Album Covers.....	73
Howard Negative Preserver and Binder.....	74
Hard Rubber Plates.....	81
Hallenbeck Sensitized Paper and Dry-Plate Safety Box.....	89
Hypo Eliminator.....	96
I	
Instantaneous Shutters.....	57
Instantaneous Outfit, The 1888.....	19
J	
Japanned Developing Trays.....	103

LP1818

INDEX.

	PAGE	PAGE	
K			
Kellogg Instantaneous Shutter...	58	Photographic Series..... 108	
Keystone Dry Plates.....	105	Photo-Micrographic Camera..... 40	
L			
Lanterns.....	93, 94	Protecting Cases..... 98	
Lantern Slide Boxes.....	91	Print Mounter..... 101	
Lantern Transparencies.....	107	Photographic Publications..... 109	
Light-Weight Double Holders....	82	Photographic Reference Books... 109	
Lenses, Beck.....	55	Petite Lanterns..... 93	
Lenses, Darlot.....	56	Prepared Developers..... 96	
Lenses, Steinheil.....	48-54	Printing Frames, Irving..... 90	
Lenses, Morrison.....	42	R	
Lenses, Waterbury.....	41	Revolving-back Camera..... 29	
Lenses, Ross.....	47	Rubber Trays..... 100	
Lenses, Wale.....	44	Rubber Plates..... 81	
Lenses, Portrait.....	43	Reversing Attachment..... 89	
Lenses, Peerless Stereo.....	43	Roll Holders..... 63, 64	
M			
Manifold Cameras.....	30	Ross Lenses..... 47	
Mercer Photo-micrographic Cam- era.....	40	Ready-sensitized Albumen Paper. 75	
Magic Finders.....	61	Registering Slides..... 83	
Metallic Protecting Cases.....	98	Rabbit Kit Frames..... 83	
Manipulator.....	102	Russell Negative Clasps and Racks for Drying..... 92	
Multum in Parvo Dry-Plate Lan- tern.....	94	S	
Magnesium Cartridges.....	65, 66	St. Louis Reversible Back Cam- eras..... 27	
N			
Ne Plus Ultra Outfits.....	12, 13	Solutions, Ready Prepared..... 96	
New York Dry-Plate Outfits.....	18	Steinheil Lenses..... 48-54	
Negative Boxes.....	91	Squeegees..... 81	
Negative Paper.....	78	Shutters, Universal Safety..... 57	
Negative Clasp.....	92	Scholars' Outfits..... 17	
Negative Washing Boxes.....	97	Scovill Dry Plate Holder..... 84	
O			
Opal Glass for Transferotypes....	77	T	
Outfits for Making Lantern Slides	100	Transferotype Paper..... 77	
Outfits for Copying Drawings... 52,	53	Transparency Frames..... 99	
Outfits for American Scholars....	17	Tourist Pocket Outfits..... 35	
Outfits for Making Blue Prints... 16	16	Thin Gold Beveled Edge Cards... 67	
Outfits for Photographing with Microscope.....	39	Translucine..... 81	
Orthochromatic Plates.....	105, 106	Tripods, Adjustable..... 87	
Orthochromatic Solutions.....	96	Tripods, Jointed..... 87	
P			
Pocket Photo Outfits for Bicyclists	35	Tripods, Daisy..... 88	
Photo-microscopic Equipment... 39	39	Tripods, Extension..... 85	
Petite Camera.....	40	Tripods, Taylor..... 77, 88	
Porte-Feuille.....	69	Tripods, Albion..... 86	
Perfect Preserving Tubes.....	76	U	
Peerless Dark-Room Lanterns....	93	Universal Shutters..... 57	
Pyro and Potash Developer.....	95	V	
Pelletone.....	95	View Albums..... 68	
Plain Ground-Glass for Transpar- encies.....	99	W	
Photographic Times Almanac....	110	Waterbury Outfits..... 20	
Plate Lifter.....	92	Waterbury Detective Cameras... 32	
		Walmsley's Photo-micrographic Cameras... 37, 38	
		Waterbury Lenses..... 41	
		Wale Lenses..... 44	
		Waterbury Focusing Glass..... 62	
		Waterbury Finders..... 62	
		Wilson's Photographic Publica- tions..... 113	
		Washing-Boxes..... 97	

ISSUED EVERY FRIDAY.
Monthly Edition Issued the Last Friday in the Month.

The Photographic Times

And AMERICAN PHOTOGRAPHER.

A SPECIMEN COPY FREE.

SUBSCRIPTIONS.

One Copy Weekly issue, postage included to all points in U. S. or Canada.....	\$3.00
One Copy Monthly issue, postage included, to all points in U. S. or Canada.....	2.00
Weekly issue to foreign addresses (postage included).....	4.00
Monthly issue to foreign addresses (postage included).....	3.00
Single Copy, Weekly.....	10
Monthly.....	25

ADVERTISING RATES.

Size of advertising pages, 6 1/2 x 9 1/2 inches; outside size, 8 1/2 x 11 1/2 inches.

Cards, 2 1/2 x 3 inches, per insertion.....	\$2.50
One page, each insertion, in either Weekly or Monthly edition.....	20.00
Half page, per insertion.....	10.00
Quarter page, per insertion.....	5.00
Discount for term contracts.	
Business Notices, not displayed, per line.....	15

Scovill Mfg. Co., Publishers,
W. IRVING ADAMS, Agent.